

HIGH-VOLTAGE TRANSMISSION AND DISTRIBUTION LINE FITTINGS FOR 35–1150 kV

Products catalogue
2020



GLOBAL INSULATOR GROUP

About the company	1
Production site	2
Casting shop	3
Forging shop	3
Coupling fittings	4–31
Ball eyes of SR, SR-53-32 and SRS type	4–5
Socket eyes of U1, U1K, U1-53-32, U2, U2K, US, USK, U1-4/7-11/16 and U-40 type	5–8
Shackles of SK, SKD and SKT type	9
Yokes of K2, 2KU, 3KU, 4KU, 5KU, 8KU-53-1, 2KD, 2KD2, 3KD2, 3KB, KTZ-7-1, 2KL-12/16-1, 2KL-21-1, 3KL-21-3, 5KL-12/21-1, 5KL-40-1 and 8KL-16-2 type	10–18
Universal cast hook of KLU-16-A type	19
Links of PR, 2PR, 2PRR, PRR, PRT, PRV, PTM and PTR type	20–26
Attachment joints of KGP-9/12-3, KGP, KGT-7-1, KG-1, KG and KGN type	27–31
Suspension fittings	32–65
Suspension clamps of PG, PG-1, PB-3, PGN-1-5, PGN-2-6, PGN-3-5, PGN-2-6A, PGN-5-3, PGN-5-4, PGN-6-5, PGN-5-6, PGN-5-3PZ, PGN-5-4PZ, PGN-5-12K, PGN-6-5PZ, PGN2-5-A, 2PGN-5-1, 2PGN-5-A, 2PGN-5-7, 2PGN-5-7PZ, 2PGN-5-12K, 2PGN2-5-A, 3PGN-5-7, 3PGN-5-7PZ, 3PGN-5-A, 3PGN-5-12, 3PGN-5-12PZ, 3PGN-5-12K, 3PGN-6-12PZ, 3PGN2-5-A, 4PGN-5-12K, 4PGN2-5-12K, 5PGN-5-8 and 5PGN2-5-8 type	32–59
Suspension clamps of roller type for the long transitions	60–61
Special spacers of RS-6-400, 3RS, 4RS, 5RS, 6RS and 8RS-3-400A type	62–65
Protection fittings	66–87
Spacers of RG, 3RG, RGU, 4RG, 5RG, 6RG-5-400, 8RG, RU, RGIF and R type	66–72
Spacer-dampers of RD and 3RD type	71–72
Intraphase spacers-dampers of distant type for bundle conductors of overhead transmission lines up to 750 kV	73–75
Vibration dampers of GPG and GV-0.4/0.8/9.1-24 type	76–79
Vibration multiresonant dampers of GVM type	80
Vibration dampers of excentric weights of GP type and pendulums of MP type	81
Arcing horns of RR, RRN and RRV type	82–83
Shield of EO-640/600-1 type	84
Bolted clamps of PAB type	84
Ballast weights	85–86
Attachment fitting for shield of UKE-1A and UKE-1B type	87
Tension fittings	88–98
Thimble clevis wedged tension clamps of NKK type	88
Wedged tension clamp of NK-1-1 type	89
Tension clamp of NB-1, NB-2-6 and NB-3-6B type	90–91
Wedge-operated tension clamp of NZ-2-7 type	91
Compression tension clamps of NAS type	92–93
Compression tension clamps of NAS-M type	94
Transposition tension clamps of TRAS type	95
Compression tension clamps of NS type	96–97
Wedge-type tension clamps of ZNK type	98
Connection fittings	99–104
Connectors of SVS type	99
Bolted coupling clamps of PS type	99
Compression type earthing clamps	100
Bolted coupling clamps of PA type	101
Compression coupling clamps of SAS type	102
Corrosionproof automatic connectors	103–104
Screwed pin	104
Stay clamp for towers	105
Mounting fixture of MI-363 type	105



GLOBAL INSULATOR GROUP

Global Insulator Group (GIG) is an international industrial holding investing in production and development in the field of glass, composite, porcelain insulation and line fittings. The basic enterprises – Yuzhnouralsky Insulators and Fittings Plant, YuAIZ AO (Russia), Lviv Insulator Company LLC (Ukraine), Kazakh Insulators and Fittings Plant (Kazakhstan), and modern production of composite insulators GIG Polymer (Estonia).

Suspension disc-type glass insulators – 13 million units per year. Suspension string toughened glass insulators for HVTL and substations for the voltage range of 35–1150 kV for AC systems and up to 800 kV for DC lines as well.

Porcelain insulators – 7 000 ton per year. Porcelain insulators for HVTL for the voltage range of 0.4–20 kV and for 0.4–110 kV substations.

Composite insulators – 500 000 units per year. Line suspension insulators for voltage of 15–765 kV, pin insulators for traction lines, line post insulators, post insulators for substations and hardware-controlled insulators for 765 kV.

High-voltage transmission and distribution line fittings – 4 000 ton per year, for 35–1150 kV HVTL.

More than 300 companies from Russia, the CIS countries and from more than 100 countries of Europe, America, Africa, Middle East, Asian-Pacific region are the constant consumers of the holding's products. The wide geography of deliveries provides manufacturing of the insulation units for different environmental conditions.

The new constructive designs are based on the 60-year-old operating experience in the field of insulation at the important high-voltage objects in harsh environmental conditions. Thanks to constant cooperation of **GIG** technical centre with the TL service departments there were developed the products with special requirements: Super-FOG glass insulators, glass insulators with a waterproof (composite) coating, insulators for DC lines, pin glass-porcelain insulators, seamless composite insulators for HVTL and substations up to 500 kV, line fittings for tight and high-temperature conductors.

The products of **Global Insulator Group** comply with the quality management systems of ISO 9001, 14001, and 18001. The products are subjected to testing in the factory laboratories and international independent test centers to confirm the customer's requirements and national standards.

Technical support of the **GIG** clients is carried out by the technical consulting service "GIG-Operation division".

Yuzhnouralsky Insulators and Fittings Plant (YuAIZ AO)

Yuzhnouralsky Insulators and Fittings Plant (YuAIZ AO) was founded in 1957 and now it is a unique enterprise in the energy sector, uniting several production facilities in the same area: glass insulator production, porcelain insulator production, forging and casting workshops.

In 1996 the quality management system in compliance with ISO 9001 was implemented on the plant; and in 2009 the company's planned development made the compliance with the new version of ISO 9001:2008 possible. Test Centre of YuAIZ AO has been accredited by the Federal Agency for Technical Regulation and Metrology, and meets requirements of the Russian State standard GOST R ISO/IEC 17025:2006 and international standard ISO/IEC 17025:2005.

Environmental management system and Labor protection system meet the requirements of international standards ISO 14001:2004 and BS OHSAS 18001:2007 respectively.

As part of the investment program the new glass furnace was installed in 2006. In the beginning of 2008 WALTEC production line for the manufacturing of glass insulating parts was put into operation (second WALTEC line was installed in 2013).

Today the comprehensive modernization process of the enterprise is continuing.

The production of YuAIZ is subjected to type and periodical tests in independent national and international test centers. The plant has the possibility to carry out additional tests according to the special requirements of the customers.

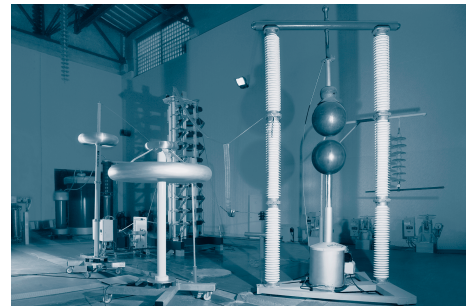
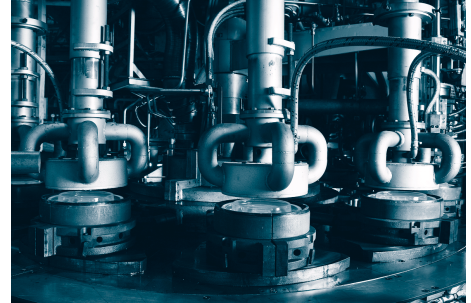

Certificate of compliance ISO 9001:2015



Certificate of compliance ISO 14001:2015



Certificate of compliance BS OHSAS 18001:2007

Manufactured in YuAIZ casting shop are:

- High-strength cast iron caps for assembly of string insulator units.
- High-strength cast iron castings for line fittings and post insulators.
- Grey cast iron castings for line fittings.
- Aluminium alloy castings for post insulators and for line fittings.
- Tailored castings from cast iron and aluminium alloy.

Cast iron chemical composition, thermal treatment modes, cast iron structure, mechanical parameters of cast iron and castings, quality of zinc coating, other process parameters are monitored throughout the process.

Casting process is monitored by the relevant laboratory which functions as part of the production shop. Mechanical properties of cast iron and castings are checked by the relevant laboratory of the Quality Control Department.

Upon completion of the production process, lots of castings undergo the sample tests in compliance with requirements prescribed by Specifications.



The forge is in charge of manufacturing line fittings for high-voltage power transmission lines (35, 110, 220, 330, 500, 750, 1150 kV) as well as of manufacturing parts for insulators.

The line fittings represent one of plant's major types of products.

The nomenclature includes the following kinds of products: coupling fittings, suspension fittings, protection fittings, tension fittings, connection fittings.

The production is focused on manufacturing line fittings required for securing complete delivery sets for Customers.



Ball eyes of SR type

Ball eyes of SR type are intended for assembling insulating strings of overhead power line conductors and earthwires.

Ball of the ball eye couples with an insulator cap or a socket eye.

Socket dimensions of caps and socket eyes should comply with the ball dimensions of the ball eyes as specified in GOST 27396-93.

Coupling dimensions comply with GOST 11359-75 requirements.

Ball eyes meet TU 3449-105-00111120-94 requirements.



Reference designation	Dimensions, mm				Minimum failing load, kN	Weight, kg
	d	D	b	H		
SR-4-11	11.9	15	14	50	40	0.12
SR-7-16	17	17	16	65	70	0.3
SR-12-16	17	23	22	65	120	0.41
SR-16-20	21	26	25	70	160	0.55
SR-21-20	21	29	28	80	210	0.65
SR-30-24	25	38	36	100	300	1.35
SR-40-28	29	42	40	120	400	1.73

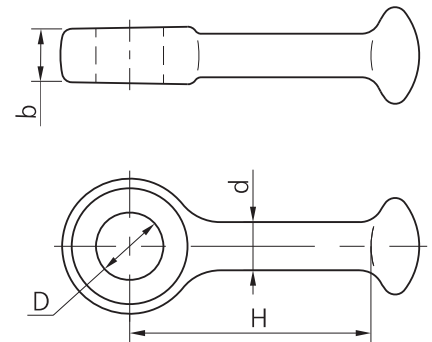

Ball eye of SR-53-32 type

Ball eye of SR-53-32 type is intended for assembling insulating strings of overhead power line conductors and earthwires.

Ball of the ball eye couples with an insulator cap or a socket eye.

Socket dimensions of caps and socket eyes should comply with the ball dimensions of the ball eyes as specified in GOST 27396-93.

Coupling dimensions comply with GOST 11359-75 requirements.

Ball eye meet TU 3449-105-00111120-94 requirements.

Reference designation	Dimensions, mm						Minimum failing load, kN	Weight, kg
	b	D	D1	d	H	H1		
SR-53-32	42	90	44	33	200	125	530	2.53

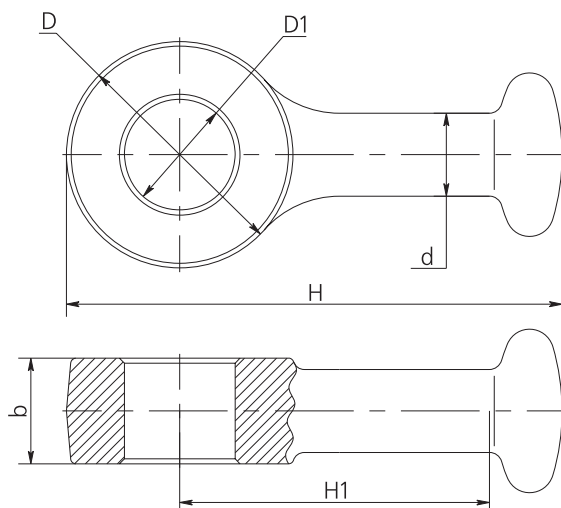

Ball eyes of SRS type

Ball eyes of SRS type are intended for assembling insulating strings of overhead power line conductors and earthwires.

Ball of the ball eye couples with an insulator cap or a socket eye.

Socket dimensions of caps and socket eyes should comply with the ball dimensions of the ball eyes as specified in GOST 27396-93.

Coupling dimensions comply with GOST 11359-75 requirements.

Ball eyes meet TU 3449-105-0011120-94 requirements.

Reference designation	Dimensions, mm				Minimum failing load, kN	Weight, kg
	d	D	b	H		
SRS-4-11	11.9	17	11.9	46.5	40	0.12
SRS-7-16	17	23	17	65	70	0.32
SRS-7-16A	17	17	15	55.5	70	0.26

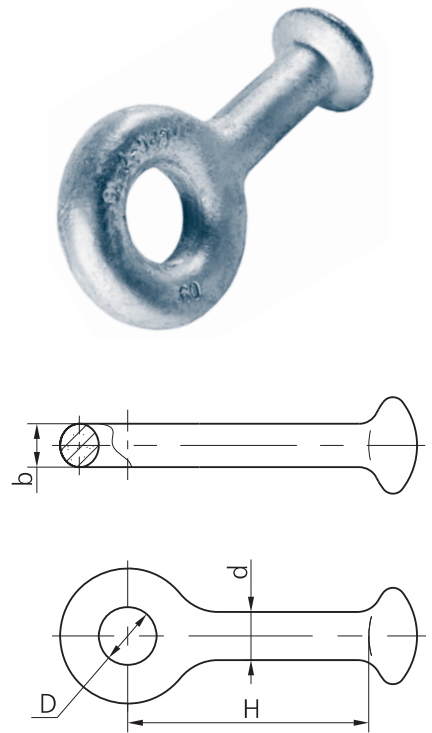

Socket eyes of U1 and U1K type

Socket eyes of U1 and U1K type are intended for coupling a pin of a string insulator unit or a ball eye with another line fitting.

Socket of the ball and socket coupling of the socket eye is designed in compliance with GOST 27396-93.

Coupling dimensions comply with GOST 11359-75 requirements.

Socket eyes are supplied complete with W-clips intended for locking of insulator pins or ball eye balls.

Socket eyes meet TU 3449-111-0011120-95 requirements.

Reference designation	Dimensions, mm				Minimum failing load, kN	Weight, kg
	H	A	B	D		
U1-4-11	80.5	12.5	14	15	40	0.53
U1-7-16	96.5	19.2	16	17	70	0.62
U1-12-16	102.5	19.2	22	23	120	1.05
U1-16-20	113.5	23	25	26	160	1.6
U1-21-20	130.5	23	28	29	210	2.24
U1-30-24	150	27.5	36	38	300	5.04
U1K-7-16	77	19.2	16	17	70	0.57

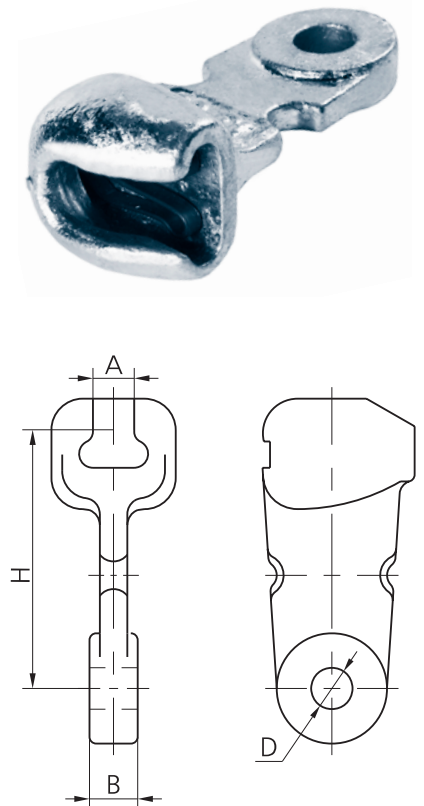

Socket eye of U1-53-32 type

Socket eye of U1-53-32 type is intended for coupling a pin of a string insulator unit or a ball eye with another line fitting.

Socket of the ball and socket coupling of the socket eye is designed in compliance with GOST 27396-93.

Coupling dimensions comply with GOST 11359-75 requirements.

Socket eye is supplied complete with W-clips intended for locking of insulator pins or ball eye balls.

Reference designation	Dimensions, mm							Minimum failing load, kN	Weight, kg
	B1	B2	b	D	D1	H	H1		
U1-53-32	122	125	42	44	36	190	265	530	9.4

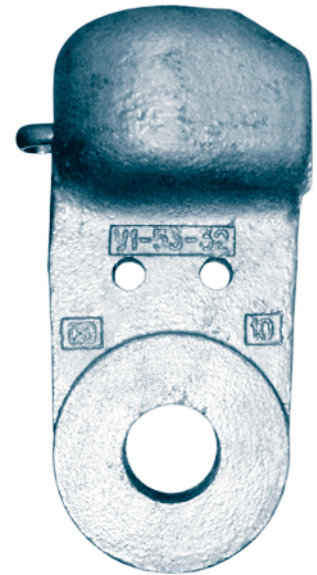
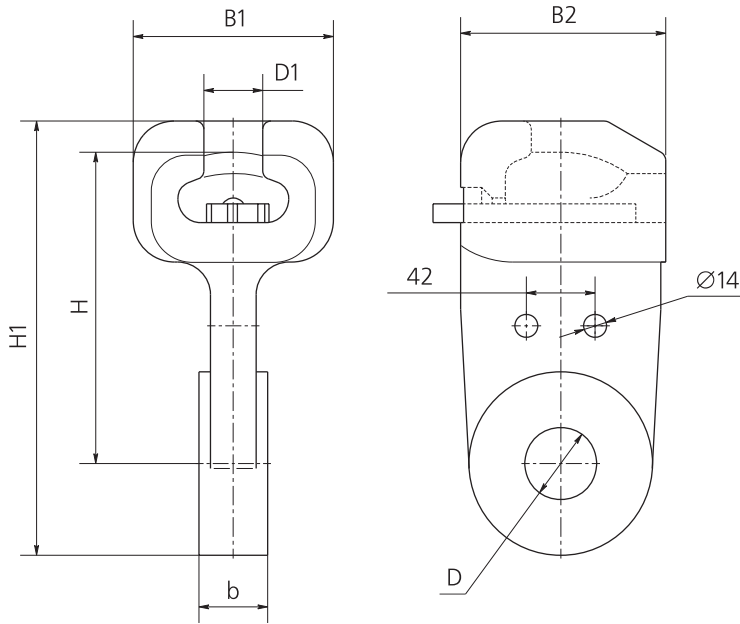

Socket eyes of U2 and U2K type

Socket eyes of U2 and U2K type are intended for coupling a pin of a string insulator unit or a ball eye with another line fitting. Socket eyes meet TU 3449-111-0011120-95 requirements.

Reference designation	Dimensions, mm				Minimum failing load, kN	Weight, kg
	H	A	B	d		
U2-7-16	95.5	19.2	17	16	70	0.98
U2-12-16	102.5	19.2	23	22	120	1.52
U2-16-20	113.5	23	26	25	160	2.17
U2K-7-16	77	19.2	17	16	70	0.75

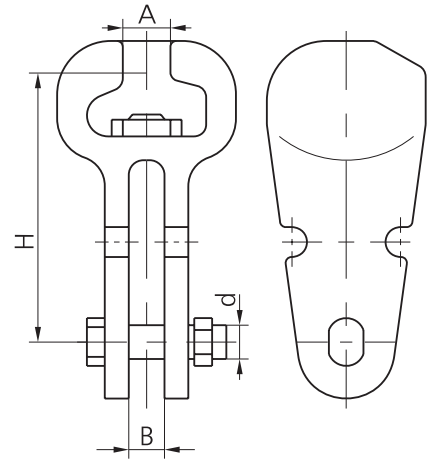
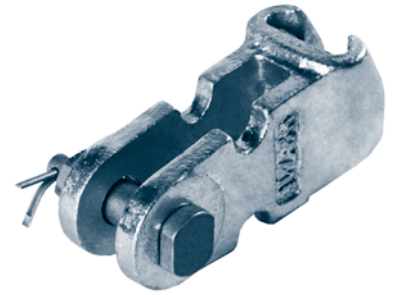

Socket eyes of US and USK type

Socket eyes of US and USK type are intended for coupling a pin of a string insulator unit with a shackle of SK type or a suspension clamp, as well as for fastening protective rings and arcing horns to them. Socket eyes meet TU 3449-111-0011120-95 requirements.

Reference designation	Dimensions, mm				Minimum failing load, kN	Weight, kg
	H	A	B	d		
US-7-16	104	19.2	110	18	70	1.25
US-12-16	113	19.2	130	25	120	2
US-16-20	132	23	146	28	160	2.9
US-21-20	145	23	168	28	210	4.71
USK-7-16	67	19.2	110	18	70	1.2
USK-12-16	78	19.2	130	25	120	2.1
USK-16-20	90	23	142	28	160	3.5
USK-21-20	90	23	168	28	210	4.17

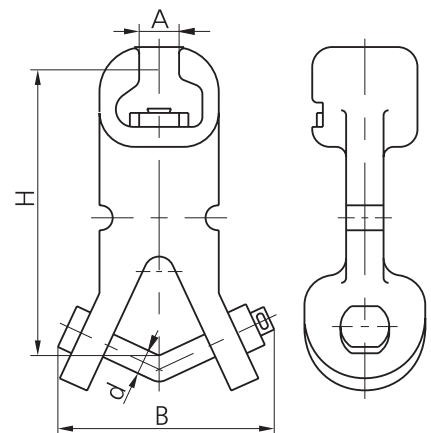

Socket eye of U1-4/7-11/16 type

Socket eye of U1-4/7-11/16 type is intended for coupling a pin of a string insulator unit or a ball eye with another line fitting.

Socket of the ball and socket coupling of the socket eye is designed in compliance with GOST 27396-93.

Coupling dimensions comply with GOST 11359-75 requirements.

Minimum failing load – 40 kN. Weight – 0.22 kg.

Socket eye meet TU 3449-111-00111120-95 requirements.

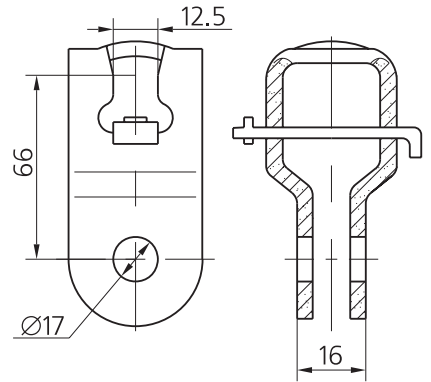

Special-purpose socket eye of U-40 type

Special-purpose socket eye of U-40 type is intended for coupling a pin of a string insulator unit or a ball eye with another line fitting.

Coupling dimensions comply with GOST 11359-75 requirements.

Minimum failing load – 35 kN. Weight – 0.15 kg.

Socket eye meet TU 3449-111-00111120-95 requirements.

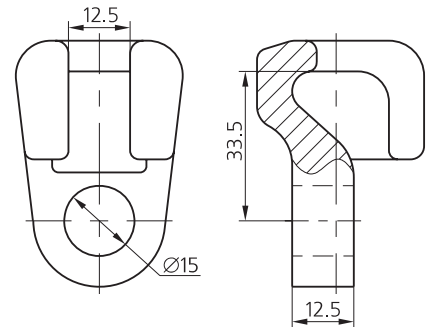

Shackles of SK and SKD type

Shackles of SK and SKD type are intended for converting from "ball and socket" coupling to "clevis-tongue" coupling and for connecting line fittings intended for different mechanical ratings.

Shackles meet TU 3449-107-0011120-94 requirements.

Reference designation	Dimensions, mm				Minimum failing load, kN	Weight, kg
	B	H	d	d1		
SK-4-1	15	45	10	14	40	0.2
SK-7-1A	17	50	14	16	70	0.38
SK-12-1A	23	65	18	22	120	0.95
SK-16-1A	26	70	20	25	160	1.22
SK-21-1A	29	75	24	28	210	1.82
SK-30-1A	38	100	28	36	300	3.3
SK-45-1A	42	100	34	40	450	5.1
SK-53-1A	44	110	36	42	530	5.89
SK-60-1A	47	125	38	45	600	6.44
SK-75-1A	52	125	40	50	750	10.9
SK-90-1A	58	150	48	56	900	12.22
SK-110-1A	62	150	53	60	1100	16.43
SK-120-1	67	180	60	65	1200	21.65
SK-135-1	72	180	60	70	1350	23.2
SK-180-1	83	220	70	80	1800	35.9
SK-270-1	111	270	85	108	2700	66
SK-360-1	128	320	95	125	3600	111.7
SKD-10-1	19	80	16	18	100	0.67
SKD-12-1	23	82	18	22	120	1.16
SKD-16-1	26	105	20	25	160	1.36
SKD-21-1	29	115	24	28	210	2
SKD-45-1	42	170	34	40	450	6.03

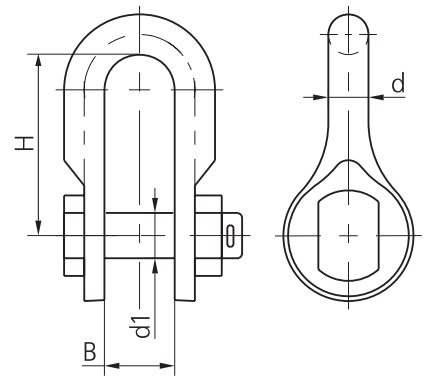

Shackles of SKT type

Shackles of SKT type are intended for coupling line fittings with different mechanical ratings, for twisting the pivoting axis by 90°.

Shackles meet TU 3449-107-0011120-94 requirements.

Reference designation	Dimensions, mm					Minimum failing load, kN	Weight, kg
	H	B	b	D	d		
SKT-4-1	60	15	14	15	14	40	0.24
SKT-7-1	60	17	16	17	16	70	0.46
SKT-12-1	70	23	22	23	22	120	0.95
SKT-16-1	80	26	25	26	25	160	1.52
SKT-21-1	90	29	28	29	28	210	1.96
SKT-30-1	110	38	36	38	36	300	3.53
SKT-45-1	120	42	40	42	40	450	6.57
SKT-53-1	130	44	42	44	42	530	7.48
SKT-60-1	150	47	45	47	45	600	9.7

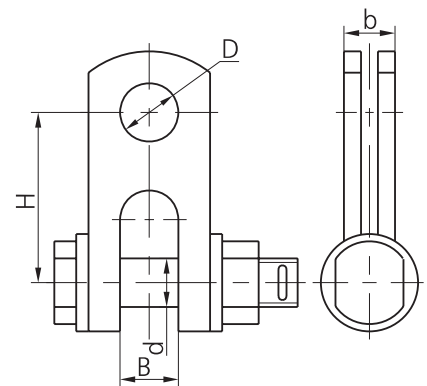
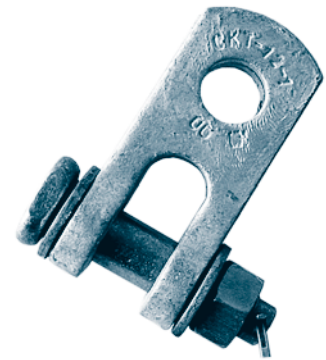

Yokes of K2 type

Yokes of K2 type are intended for fastening two phase conductors of power lines to single insulating strings.

Yokes meet TU 3449-112-0011120-95 requirements.

Reference designation	Dimensions, mm				Minimum failing load, kN	Weight, kg
	B	C	H	D		
K2-7-1S	16	120	70	17	70	1.5
K2-12-2	22	150	60	23	120	2.5

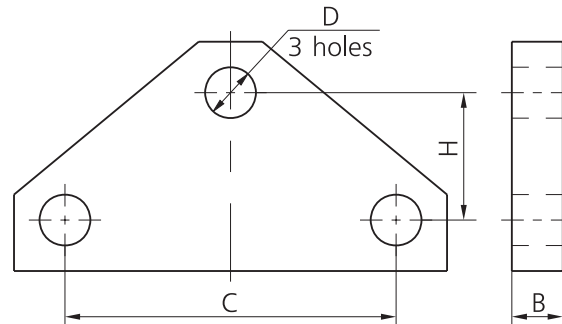

Universal yokes of 2KU type

Universal yokes of 2KU type are intended for supporting two insulating strings and for fastening two phase conductors to insulating strings of power lines.

Universal yokes meet TU 3449-112-0011120-95 requirements.

Reference designation	Dimensions, mm					Minimum failing load, kN	Weight, kg
	B	L	R	d	H		
2KU-12-1	20	400	10	23	190	120	4.66
2KU-12-1A	20	400	10	23	190	117.7	4.8
2KU-12-2	20	600	10	30	315	117	11.4
2KU-30-1	30	450	15	34	213	300	9
2KU-45-1	36	400	18	42	183	450	10.7
2KU-60-2	43	450	21.5	38	250	600	16.5
2KU-90-1A	48	450	24	34	201	900	25
2KU-135-1	60	600	26	—	340	1350	44.3
2KU-180-1	70	600	28	—	412	1800	64.45

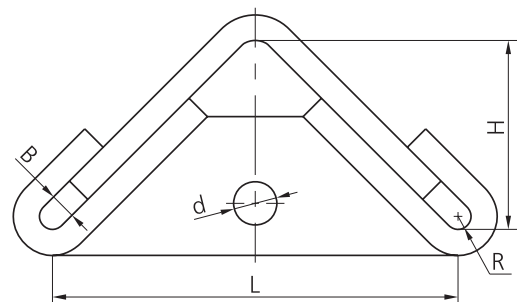

Universal yokes of 3KU type

Universal yokes of 3KU type are intended for fastening three phase conductors to the insulating string on transmission lines. The yokes ensures chain-type coupling. Universal yokes meet TU 3449-112-0011120-95 requirements.

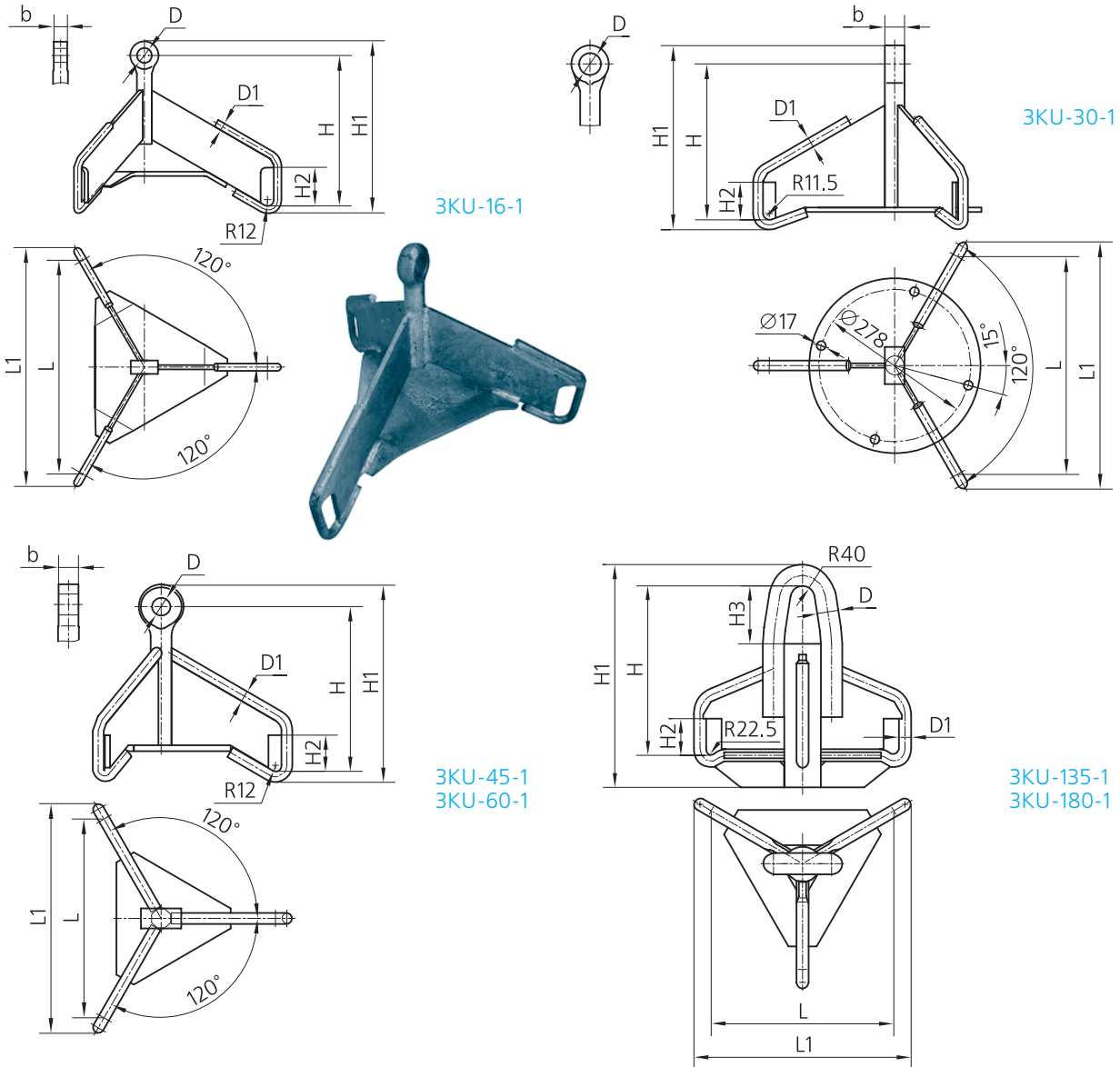

Reference designation	Dimensions, mm									Minimum failing load, kN	Weight, kg
	D	D1	b	H	H1	H2	H3	L	L1		
3KU-16-1	26	14	25	280	320	70	—	400	445	160	9
3KU-30-1	38	18	36	290	344	68	—	400	454	300	15.3
3KU-45-1	42	22	40	330	395	70	—	400	462	450	20.2
3KU-60-1	47	24	45	350	424	90	—	400	471	600	26.2
3KU-135-1	60	36	—	485	625	120	195	400	498	1350	68
3KU-180-1	70	40	—	555	730	120	190	600	713	1800	143

Universal yokes of 4KY and 5KY type

Universal yokes of 4KU, 5KU type are intended for fastening four and five phase conductors to the insulating string on transmission lines. The yokes ensures chain-type coupling.

Universal yokes meet TU 3449-112-00111120-95 requirements.

Reference designation	Minimum failing load, kN	Weight, kg
4KU-45-1	450	28.5
5KU-25-1	250	33.5
5KU-60-1	600	76

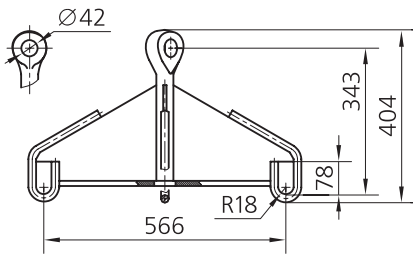

4KU-45-1

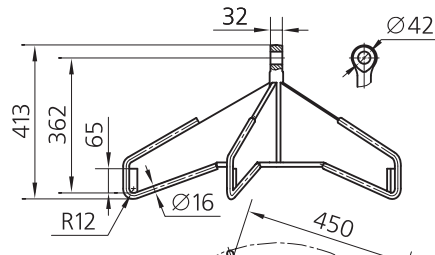
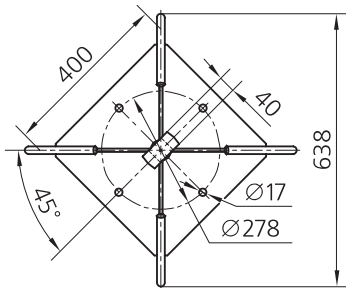

5KU-25-1

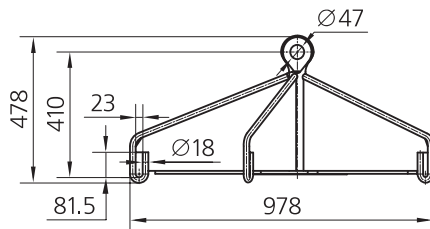
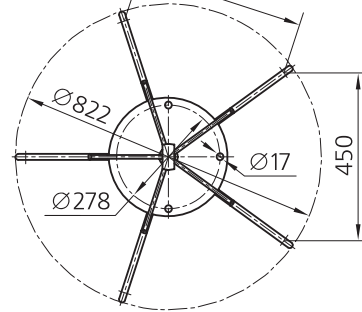

5KU-60-1

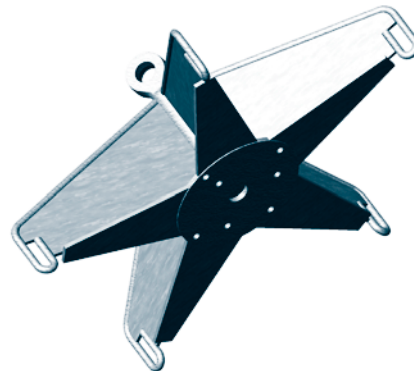
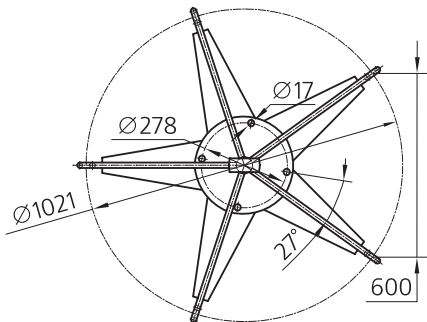

Universal yoke of 8KU-53-1 type

Universal yoke of 8KU-53-1 type is intended for fastening eight phase conductors to the insulating string on transmission lines. The yoke ensures chain-type coupling. Universal yoke meet TU 3449-112-00111120-95 requirements.

Reference designation	Minimum failing load, kN	Weight, kg
8KU-53-1	530	66.8

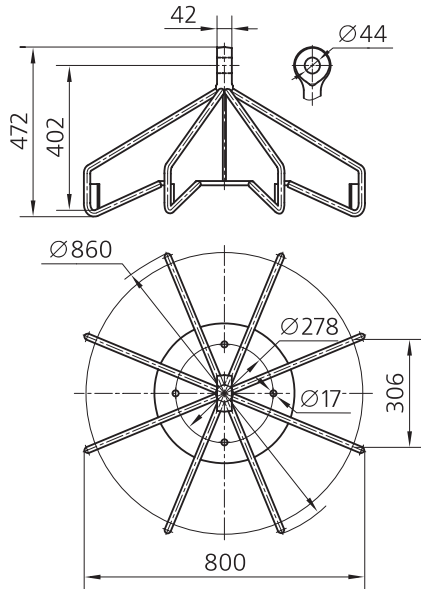

8KU-53-1



Yokes of 2KD type

Yokes of 2KD type are intended for fastening two phase conductors of power lines to single insulating strings.

Yokes meet TU 3449-112-0011120-95 requirements.

Reference designation	Dimensions, mm				Minimum failing load, kN	Weight, kg
	C	H	B	d		
2KD-7-1S	120	70	17	16	70	1.46
2KD-12-1S	800	175	23	22	120	21.7
2KD-21-1	330	50	29.2	28	210	10.4

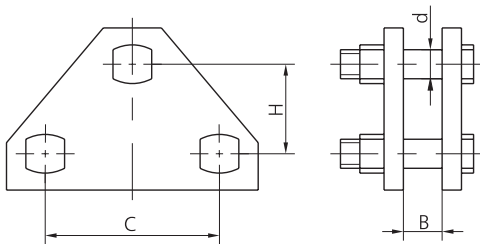
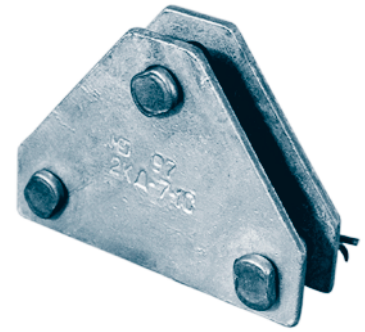

2KD-7-1S, 2KD-12-1S

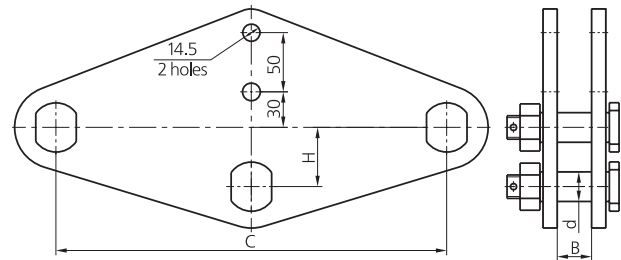

2KD-21-1

Yokes of 2KD2 type

Yokes of 2KD2 type with two attachment points are intended for two insulating strings of power lines.

Yokes meet TU 3449-112-0011120-95 requirements.

Reference designation	Dimensions, mm			Minimum failing load, kN	Weight, kg
	C	C1	H		
2KD2-240-1	2700	600	2760	2158	429
2KD2-240-2	1200	600	2953	2158	375
2KD2-240-3	2700	960	2825	2158	436

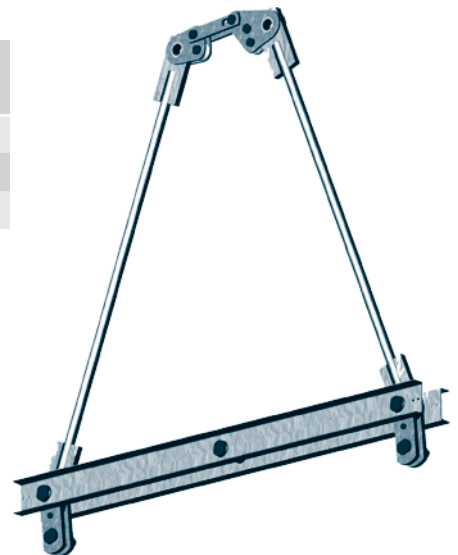
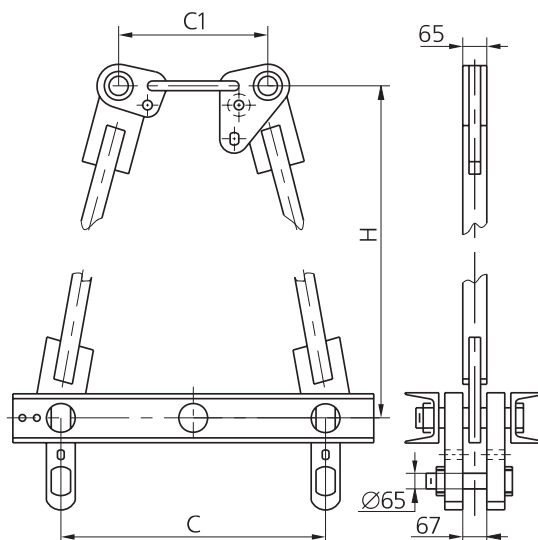

Yokes of 3KD2 type

Yokes of 3KD2 type with two attachment points are intended for three insulating strings of power lines. Yokes meet TU 3449-112-0011120-95 requirements.

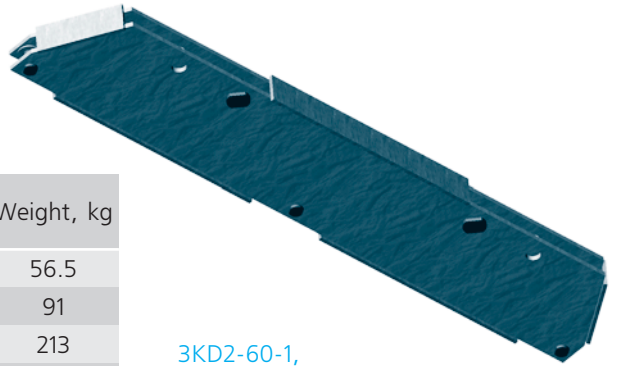

3KD2-60-1,
3KD2-120-1, 3KD2-180-1

Reference designation	Dimensions, mm							Minimum failing load, kN	Weight, kg
	L	l	H	B	b	D	d		
3KD2-60-1	600	450	160	38	29	36	28	600	56.5
3KD2-90-3	—	450	120	42	38	40	36	900	91
3KD2-120-1	1500	900	250	47	42	45	40	1200	213
3KD2-180-1	1200	1350	350	58	47	56	45	1800	457.1

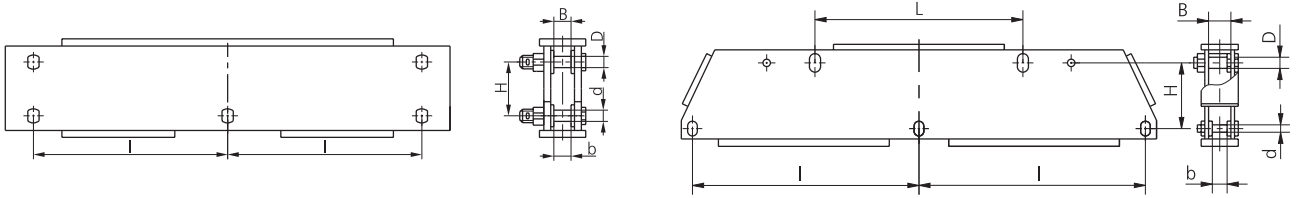

3KD2-90-3

Balancing yokes of 3KB type

Reference designation	Dimensions, mm							Minimum failing load, kN	Weight, kg
	L	H	D	B	d	d1	a		
3KB-21-1	400	665	26	17	16	—	—	210	25.8
3KB-40-1	450	750	34	23	22	—	—	400	61.2
3KB-45-1	450	753	36	26	25	—	—	450	65.8
3KB-60-1	450	780	40	29	28	—	—	600	90.8
3KB-90-1	900	1225	48	—	—	38	32	900	212
3KB-90-2	450	850	48	38	36	—	—	900	108
3KB-120-1	900	1230	60	—	—	42	40	1200	291
3KB-120-3	600	940	60	42	40	—	—	1200	188
3KB-180-2	1350	1830	70	—	—	47	45	1800	650
3KB-180-4	900	1305	70	—	—	47	45	1800	429
3KB-270-1	1350	2111	85	—	—	58	55	2700	945



Balancing yokes of 3KB type with one attachment point are intended for insulating strings of power lines. Balancing yokes meet TU 3449-112-0011120-95 requirements.

3KB-21-1 – 3KB-60-1
3KB-90-2
3KB-120-3

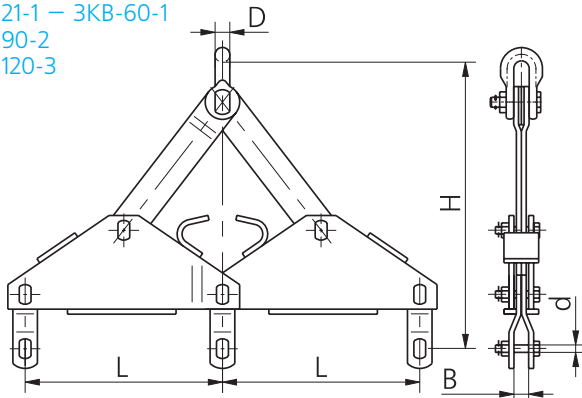

3KB-90-1
3KB-120-1
3KB-180-2 – 3KB-270-1

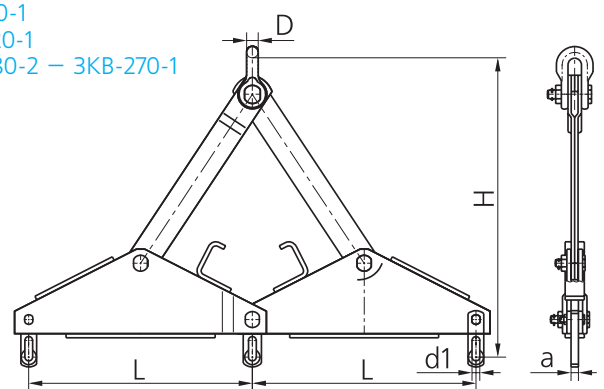

Yoke of KTZ-7-1 type

Yoke of KTZ-7-1 type is intended for fastening three phase conductors to insulating strings.

Minimum failing load – 70 kN. Weight – 1.5 kg.
Yoke meet TU 3449-112-00111120-95 requirements.

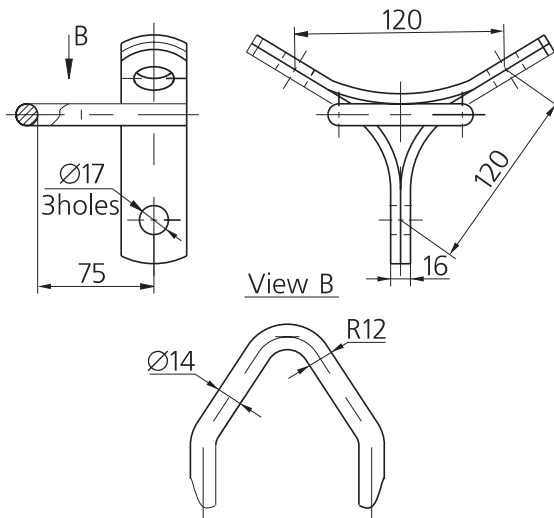

Yoke of 2KL-12/16-1 type

Yoke of 2KL-12/16-1 type is intended for uniting two tension strings of power lines.

Yoke meet TU 3449-112-00111120-95 requirements.

Yoke of 2KL-21-1 type

Yoke of 2KL-21-1 type is intended for uniting two tension strings of power lines. It possesses the higher mechanical characteristics: it is interfitted with fitting of 21-ton row.

Yoke meet TU 3449-112-00111120-95 requirements.

Reference designation	Dimensions, mm							Minimum failing load, kN	Weight, kg
	L	L1	L2	B	S	b	d		
2KL-12/16-1	660	290	225	24	12	92	22	60	14.5
2KL-21-1	680	380	300	32	16	108	28	90	27.0

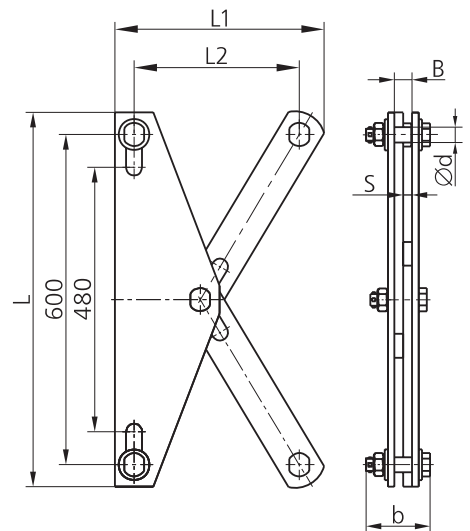

Yoke of 3KL-21-3 type

Yoke of 3KL-21-3 type is intended for uniting three tension strings of power lines.

Minimum failing load – 90 kN. Weight – 48.9 kg.
Yoke meet TU 3449-112-0011120-95 requirements.

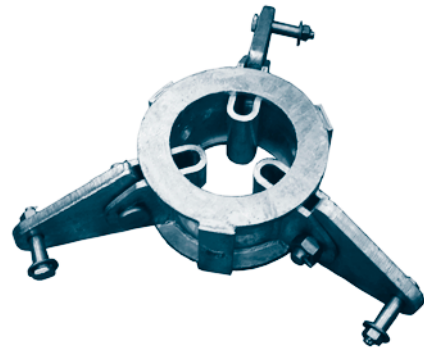
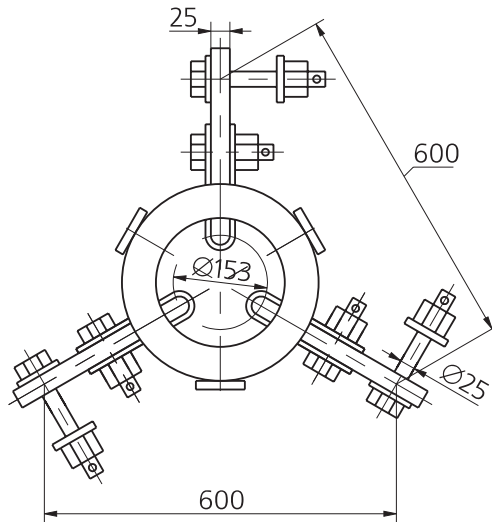

Yoke of 5KL-12/21-1 type

Yoke of 5KL-12/21-1 type is intended for uniting five tension strings of power lines.

Minimum failing load – 60 kN. Weight – 53.1 kg.
Yoke meet TU 3449-112-0011120-95 requirements.

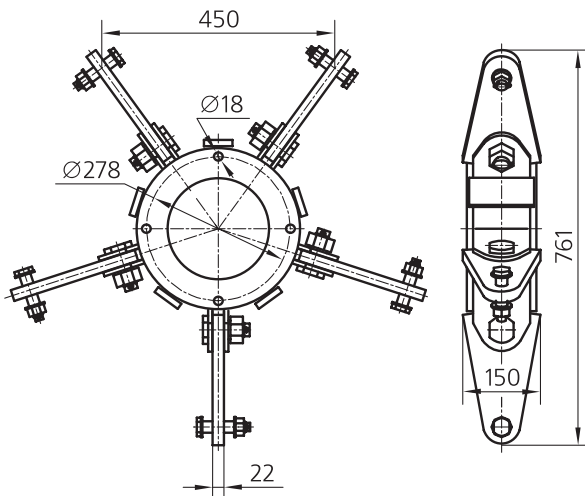

Yoke of 5KL-40-1 type

Yoke of 5KL-40-1 type is intended for uniting five tension strings of power lines.

Minimum failing load – 190 kN. Weight – 149.0 kg.

Yoke meet TU 3449-112-00111120-95 requirements.

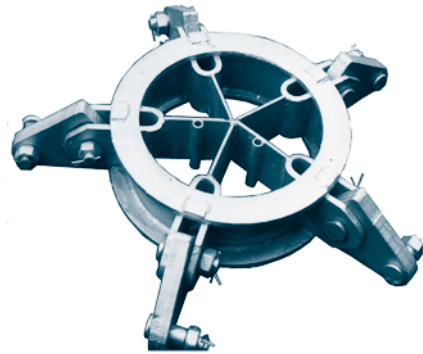
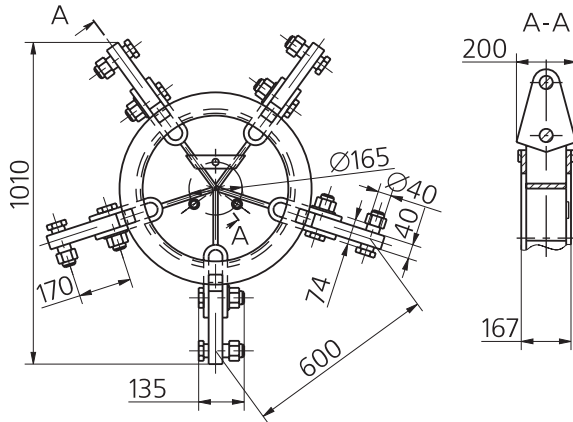

Yoke of 8KL-16-2 type

Yoke of 8KL-16-2 type is intended for uniting eight tension strings of power lines.

Minimum failing load – 75 kN. Weight – 156.6 kg.

Yoke meet TU 3449-112-00111120-95 requirements.

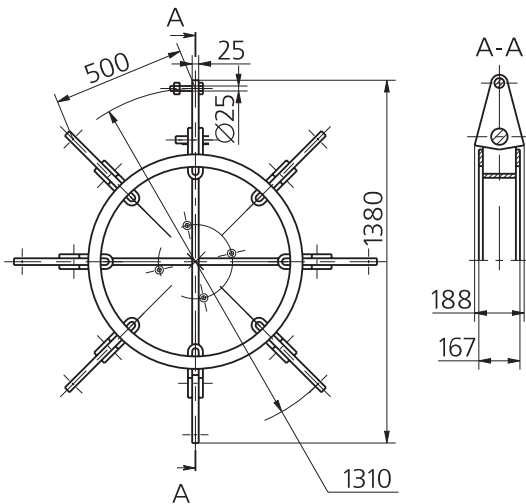

Universal cast hook of KLU-16-A type

Universal cast hook of KLU-16-A type is intended for supporting the insulated conductors in the transmission lines with voltage to 0.4 kV.

The hook is fasten to the working surface of supporting structure by means of bolts or tape.

The conductor is fixed on the hook by means of tension or suspension fittings.

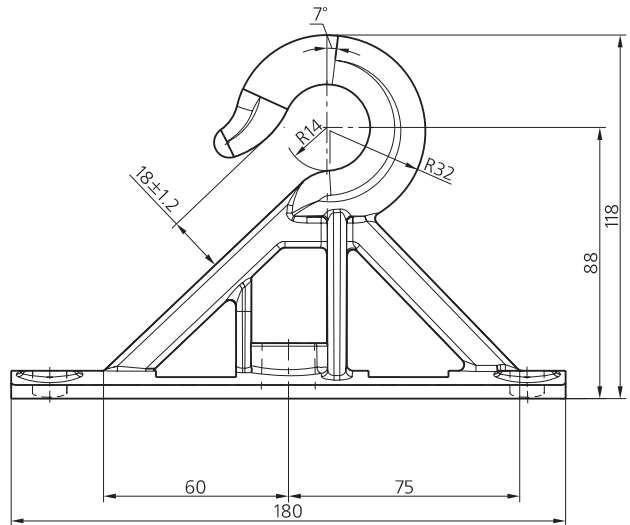

Links of PR type

Links of PR type are intended for lengthening a string.
Links meet TU 3449-109-00111120-95 requirements.

Reference designation	Dimensions, mm			Minimum failing load, kN	Weight, kg
	D	b	H		
PR-4-1	15	14	85	40	0.14
PR-7-6	17	16	70	70	0.34
PR-12-6	23	22	85	120	0.65
PR-16-6	26	25	100	160	0.98
PR-135-1	69	69	350	1350	20.4

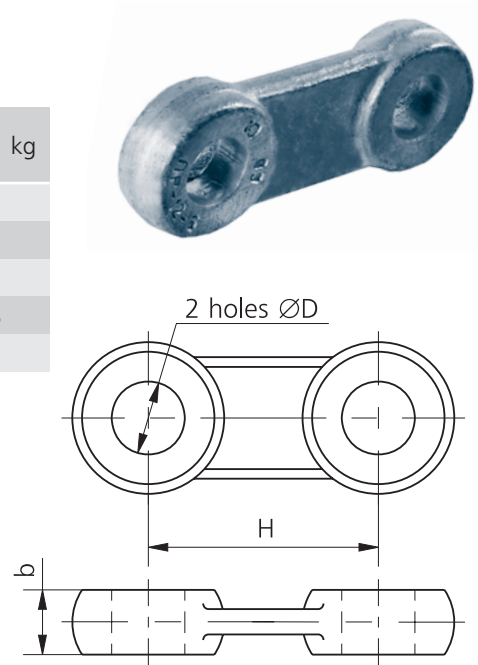

Links of PR type

Links of PR type are intended for lengthening a string.
Links meet TU 3449-109-00111120-95 requirements.

Reference designation	Dimensions, mm			Minimum failing load, kN	Weight, kg
	D	b	H		
PR-7-6	17	16	70	70	0.44
PR-12-6	23	22	85	120	0.94
PR-16-6	26	25	100	160	1.36
PR-21-6	29	28	105	210	1.75
PR-25-6	34	32	110	250	2.35
PR-30-6	38	36	130	300	3.24
PR-35-6	40	38	140	350	4
PR-45-6	42	40	150	450	5.3
PR-53-6	44	42	165	530	6.38
PR-60-6	47	45	185	600	8.9
PR-75-6	52	50	195	750	11.6
PR-90-6	58	56	215	900	14.87
PR-110-6	62	60	240	1100	20
PR-120-6	67	65	260	1200	29.6

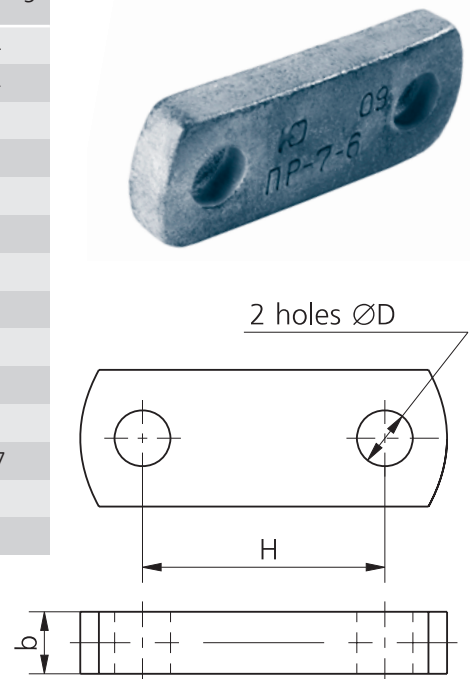

Links of 2PR type

Links of 2PR type are intended for lengthening a string.
Links meet TU 3449-109-00111120-95 requirements.

Reference designation	Dimensions, mm			Minimum failing load, kN	Weight, kg
	L	B	d		
2PR-4-1	50	15	14	40	0.33
2PR-7-1	50	17	16	70	0.54
2PR-12-1	85	23	22	120	1.25
2PR-16-1	100	26	25	160	1.87
2PR-21-1	105	29	28	210	2.73
2PR-30-1	130	38	36	300	5.31
2PR-90-1	215	58	56	900	20.95

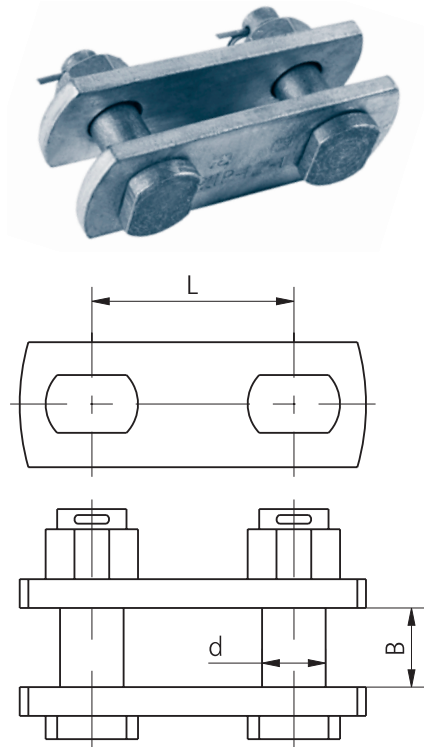

Links of 2PRR type

Links of 2PRR type are intended for lengthening a string.
Links meet TU 3449-109-00111120-95 requirements.

Reference designation	Dimensions, mm			Minimum failing load, kN	Weight, kg
	L	B	d		
2PRR-7-2	245	17	16	70	1.25
2PRR-12-2	275	23	22	120	2.17
2PRR-12-2A	245	23	22	120	1.98
2PRR-16-2	275	26	25	160	2.96
2PRR-16-2A	245	26	25	160	2.714
2PRR-21-2	375	29	28	210	4.96
2PRR-30-2	375	38	36	300	8.41

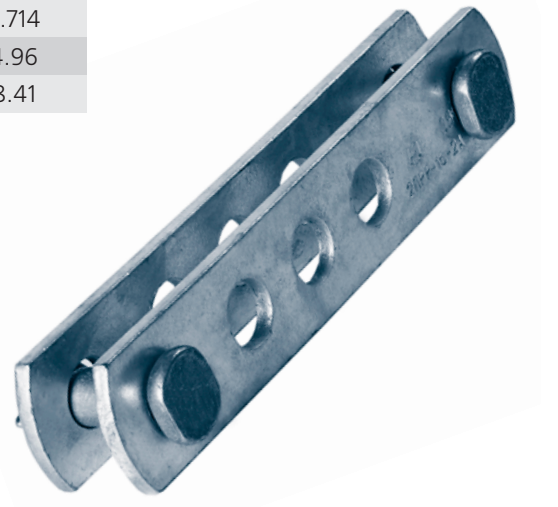
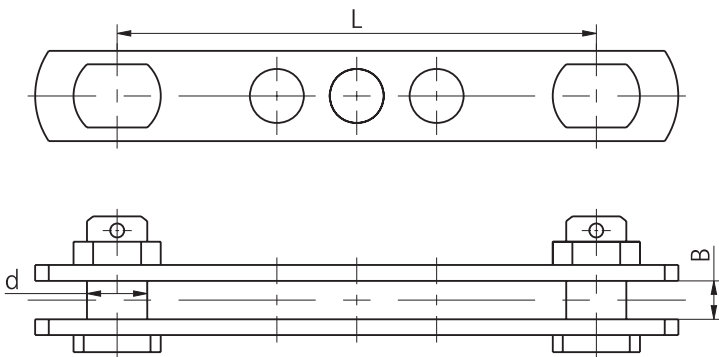

Adjustable links of PRR type

Adjustable links of PRR type are intended for stepwise length adjustment of a string. Links meet TU 3449-109-0011120-95 requirements.

Reference designation	Dimensions, mm					Minimum failing load, kN	Weight, kg
	L	B	b	D	d		
PRR-4-1	440	15	14	15	14	40	0.95
PRR-7-1	490	17	16	17	16	70	2.08
PRR-12-1	550	23	22	23	22	120	3.69
PRR-12-1A	490	23	22	23	22	120	3.9
PRR-16-1	550	26	25	26	25	160	5.0
PRR-16-1A	490	26	25	26	25	160	4.6
PRR-21-1	750	29	28	29	28	210	8.76
PRR-30-1	750	38	36	38	36	300	14.65
PRR-45-1	950	42	40	42	40	450	23.0
PRR-53-1	950	44	42	44	42	530	26.68
PRR-60-1	950	47	45	47	45	600	31.65
PRR-90-1	1400	85	56	58	56	900	62.75

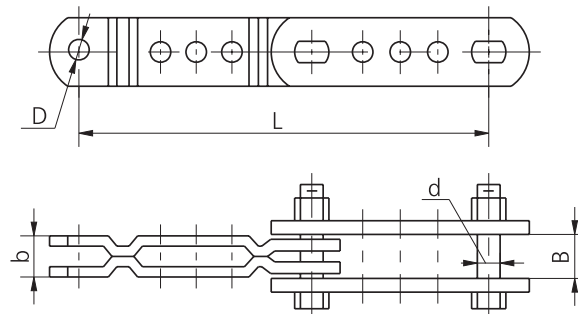
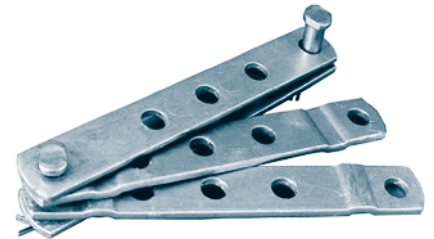

Cranked links of PRT type

Cranked links of PRT type are intended for lengthening the insulator strings, as well as for intermediating from single tongue to twin tongue. Links meet TU 3449-109-0011120-95 requirements.

Reference designation	Dimensions, mm					Minimum failing load, kN	Weight, kg
	B	b	H	D	d		
PRT-4-1	15	14	75	15	14	40	0.3
PRT-7-1	17	16	70	17	16	70	0.508
PRT-12-1	23	22	100	23	22	120	1.145
PRT-16-1	26	25	110	26	25	160	1.43
PRT-21-1	29	28	115	29	28	210	2.3
PRT-60-1	47	45	185	47	45	600	9.78
PRT-90-1	58	56	220	58	56	900	17.04

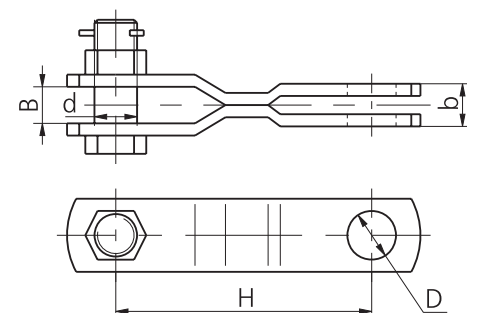

Cranked intermediate links of PRT type

Cranked intermediate links of PRT type are used as a junction between fitting of one series of load to the another series of load.
Links meet TU 3449-109-0011120-95 requirements.



Reference designation	Dimensions, mm					Minimum failing load, kN	Weight, kg
	B	b	H	D	d		
PRT-7/4-1	15	16	85	17	14	40	0.35
PRT-7/12-2	23	16	95	17	22	70	0.9
PRT-7/16-2	26	16	95	17	25	70	0.96
PRT-7/21-2	29	16	105	17	28	70	1.1
PRT-12/4-1	15	22	90	23	14	40	0.41
PRT-12/7-2	17	22	95	23	16	70	0.7
PRT-12/16-2	26	22	110	23	25	120	1.6
PRT-12/21-2	29	22	110	23	28	120	1.7
PRT-12/45-2	42	22	150	23	40	120	3.43
PRT-16/12-2	23	25	110	26	22	120	1.5
PRT-16/21-2	29	25	115	26	28	160	1.9
PRT-16/25-2	34	25	125	26	32	160	2.43
PRT-16/30-2	38	25	125	26	36	160	2.63
PRT-16/45-2	42	25	145	26	40	160	3.94
PRT-21/12-2	23	28	110	29	22	120	1.5
PRT-21/16-2	26	28	115	29	25	160	1.8
PRT-21/30-2	38	28	140	29	36	210	3.67
PRT-21/45-2	42	28	150	29	40	210	4.8
PRT-21/60-2	47	28	170	29	45	210	6.15
PRT-25/12-2	23	32	135	34	22	120	1.74
PRT-25/16-2	26	32	125	34	25	160	1.98
PRT-30/12-2	23	36	140	38	22	120	1.9
PRT-30/21-2	29	36	140	38	28	210	3.1
PRT-45/7-1	40	17	72	17	40	70	2.42
PRT-45/12-2	23	40	150	42	22	120	2.1
PRT-45/30-2	38	40	160	42	36	300	5.78
PRT-120/60-1	47	65	275	67	45	600	18.5
PRT-120/90-1	58	65	275	67	56	900	20.0

Links of PRV type

90° double links of PRV type are intended for changing the pivoting plane of the fittings being coupled.

Links meet TU 3449-109-0011120-95 requirements.

Reference designation	Dimensions, mm			Minimum failing load, kN	Weight, kg
	L	D	B		
PRV-4-1	85	15	14	40	0.14
PRV-7-1	130	17	16	70	0.43
PRV-12-1	140	23	22	120	0.74
PRV-16-1	150	26	25	160	0.91
PRV-21-1	150	29	28	210	1.3
PRV-30-1	200	38	36	300	2.5
PRV-45-1	250	42	40	450	4.1
PRV-53-1	250	44	42	530	5.9
PRV-60-1	250	47	45	600	6.5
PRV-75-1	250	52	50	750	8.2
PRV-90-1	300	58	56	900	11.2
PRV-110-1	300	62	60	1100	15
PRV-120-1	300	67	65	1200	16
PRV-135-1	350	72	70	1350	23

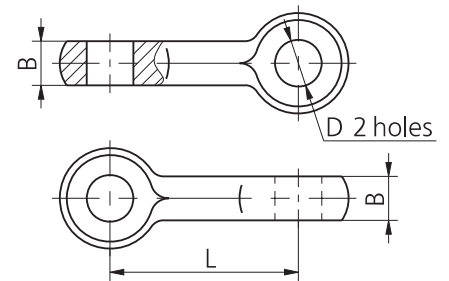

Mounting links of PTM type

Mounting links of PTM type are intended for mounting insulating strings in power lines.

Links meet TU 3449-109-0011120-95 requirements.

Reference designation	Dimensions, mm						Minimum failing load, kN	Weight, kg
	L	L1	D	B	b	d		
PTM-4-1	75	50	15	15	14	14	40	0.43
PTM-7-2	80	60	17	17	16	16	70	0.7
PTM-12-2	100	80	23	23	22	22	120	1.8
PTM-16-2	110	90	26	26	25	25	160	2.2
PTM-21-2	115	90	29	29	28	28	210	2.5
PTM-30-2	140	100	38	38	36	36	300	6.8
PTM-45-2	160	120	42	42	40	40	450	9.9
PTM-53-2	165	120	44	44	42	42	530	11.8
PTM-60-2	185	140	47	47	45	45	600	15.5
PTM-90-2	220	170	58	58	56	56	900	27.3

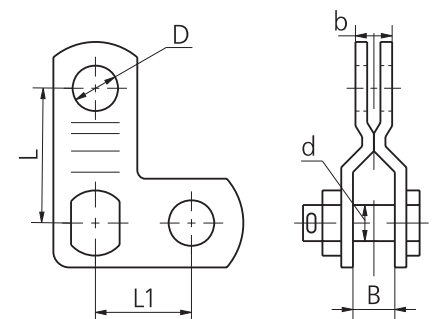
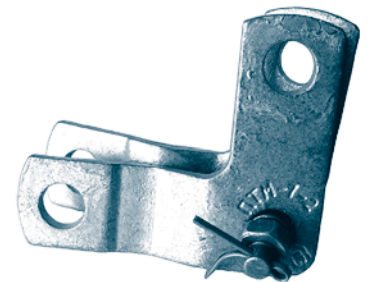

Mounting links of PTM type

Mounting links of PTM type are intended for mounting insulating strings in power lines.

Links meet TU 3449-025-59116459-2006 requirements.

Reference designation	Dimensions, mm								Minimum failing load, kN	Weight, kg
	A	A1	B1	B	D	d	L	H		
PTM-7-3	50	50	17	61	17	16	88	88	70	0.7
PTM-12-3	70	70	23	78	23	22	122	122	120	1.8
PTM-16-3	80	80	26	83	26	25	144	144	160	2.4
PTM-21-3	80	80	29	93	29	28	146	146	210	3.08

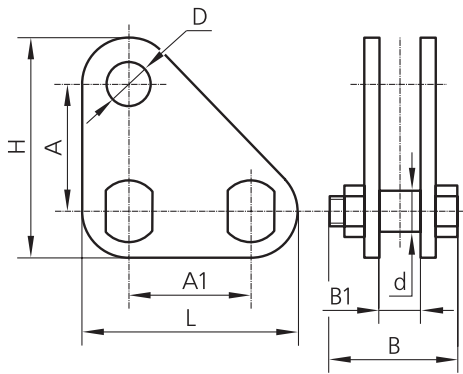

Mounting links of PTM type

Mounting links of PTM type are intended for mounting insulating strings in power lines.

Links meet TU 3449-109-00111120-95 requirements.

Reference designation	Dimensions, mm				Minimum failing load, kN	Weight, kg
	L	D	B	d		
PTM-7-3A	50	17	17	16	70	0.6
PTM-12-3A	70	23	23	22	120	1.7
PTM-16-3A	80	26	26	25	160	2.3
PTM-21-3A	80	29	29	28	210	2.9
PTM-30-3A	100	38	38	36	300	6.1

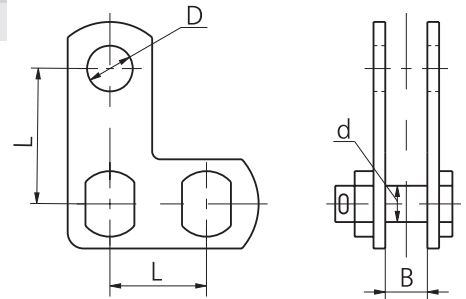
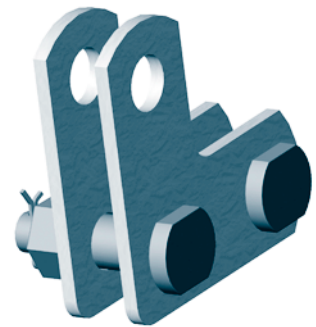

Links of PTR type

Links of PTR type are intended for fine adjustment of a string length enabled by thread on movable parts.

Links meet TU 3449-109-0011120-95 requirements.

Reference designation	Dimensions, mm						Minimum failing load, kN	Weight, kg
	L	l _{max}	l _{min}	B	d	a		
PTR-7-1	618	827	582	17	14	45	66.64	3.071
PTR-10-1	618	819	575	20	16	45	88.26	3.87
PTR-12-1	700	935	655	24	18	55	117.68	5.7
PTR-16-1	738	963	686	27	20	55	156.9	7.4
PTR-21-1	802	1015	740	30	24	65	205.94	9.9
PTR-25-1	854	1100	786	36	26	70	245.16	14.11
PTR-30-1	913	1161	836	36	28	75	294.2	18.04
PTR-60-2	1195	1460	1119	48	38	120	588.6	40.5

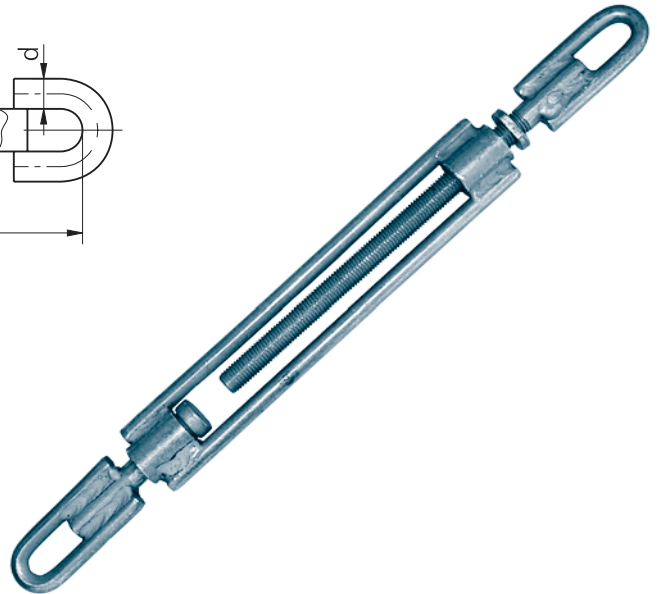
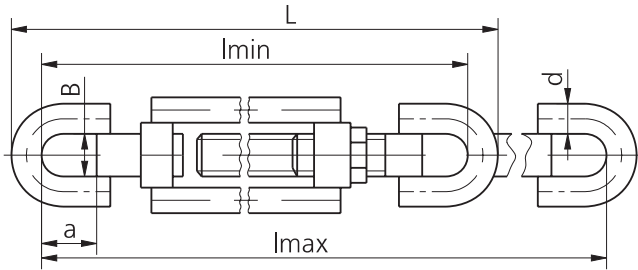

Attachment joint of KGP-9/12-3 type

Attachment joint of KGP-9/12-3 type is intended for fastening suspension insulating strings to towers of overhead power lines and switchgears. Dimensions of this attachment joint comply with the relevant dimensions of towers. Minimum failing load – 90/120 kN. Weight – 0.7 kg. Attachment joint meet TU 3449-108-0011120-94 requirements.

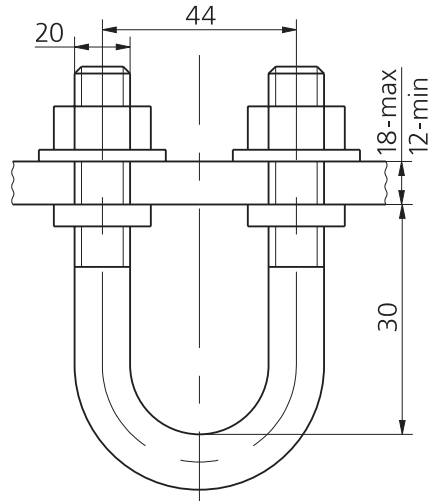

Attachment joints of KGP type

Attachment joints of KGP type are intended for fastening suspension insulating strings to towers of overhead power lines and switchgears. Dimensions of KGP type attachment joints comply with the relevant dimensions of towers. Attachment joints meet TU 3449-108-0011120-94 requirements.

Reference designation	Dimensions, mm					Minimum failing load, kN	Weight, kg
	L	H	d	a _{max}	a _{min}		
KGP-7-3	80	32	16	8	6	70	0.44
KGP-16-3	80	39	20	16	12	160	0.81
KGP-21-3	100	38	24	16	12	210	1.22

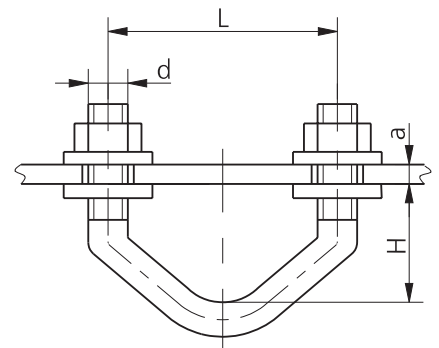
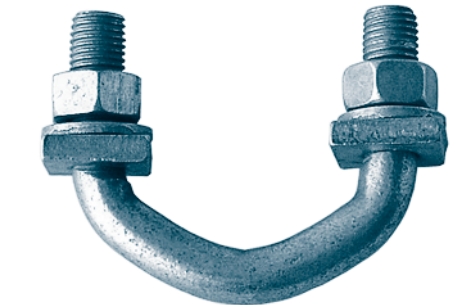

Attachment joints of KGP type (incorporating a ball eye)

Attachment joints of KGP type are intended for fastening suspension insulating strings to towers of overhead power lines and switchgears. Dimensions of KGP type attachment joints comply with the relevant dimensions of towers. Attachment joints meet TU 3449-108-0011120-94 requirements.

Reference designation	Dimensions, mm						Reference designation of incorporated ball eye	Minimum failing load, kN	Weight, kg
	L	H	H1	d	amax	amin			
KGP-7-2B	80	116	39	20	16	12	SRS-7-16	70	1.12
KGP-7-2V	80	96	32	16	8	6	SRS-7-16A	70	0.7

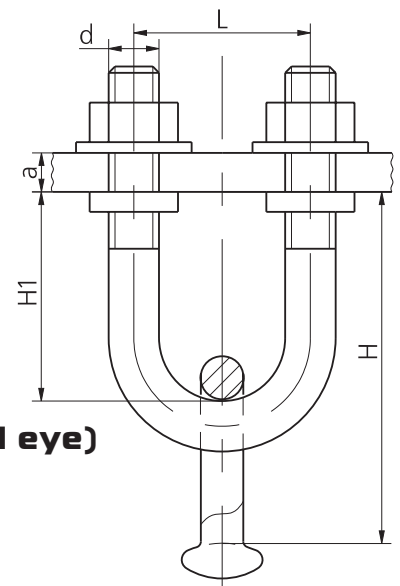
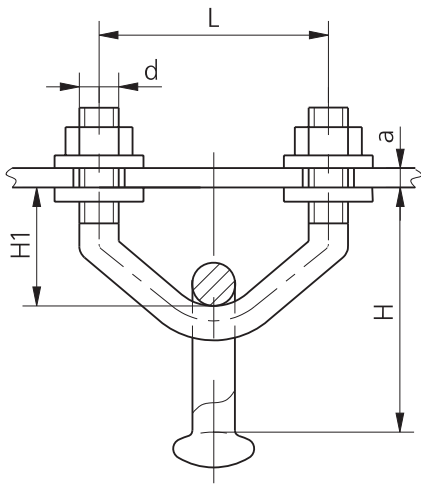

Attachment joints of KGP type (incorporating a ball eye)

Attachment joints of KGP type are intended for fastening suspension insulating strings to towers of overhead power lines and switchgears. Dimensions of KGP type attachment joints comply with the relevant dimensions of towers. Attachment joints meet TU 3449-108-0011120-94 requirements.

Reference designation	Dimensions, mm						Reference designation of incorporated ball eye	Minimum failing load, kN	Weight, kg
	L	H	H1	d	amax	amin			
KGP-7-2G	50	260	183.5	16	8	6	SRS-7-16	70	1.26
KGP-7-2D	50	280	203.5	16	8	6	SRS-7-16	70	1.28
KGP-7-1E	80	174	97.5	16	16	12	SRS-7-16	70	0.97
KGP-7-2E	80	224	147	16	16	12	SRS-7-16	70	1.15

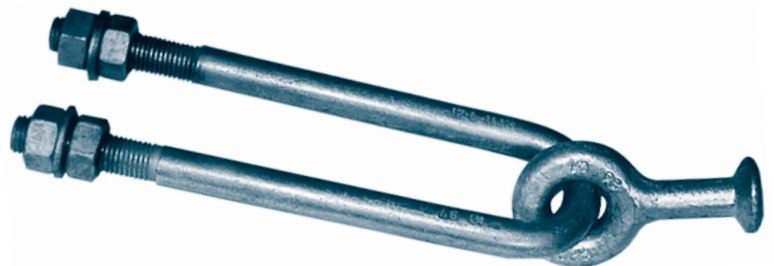

Attachment joints of KGP type (incorporating a shackle)

Attachment joints of KGP type are intended for fastening suspension insulating strings to towers of overhead power lines and switchgears.

Dimensions of KGP type attachment joints comply with the relevant dimensions of towers.

Attachment joints meet TU 3449-108-0011120-94 requirements.

Reference designation	Dimensions, mm								Reference designation of incorporated shackle	Minimum failing load, kN	Weight, kg
	L	H	H1	d	B	d1	a _{max}	a _{min}			
KGP-4-1	80	77	—	16	—	—	8	6	SK-4-1	40	0.6
KGP-7-1	80	82	18	16	17	16	8	6	SK-7-1A	70	0.8
KGP-12-1	80	104	21	20	23	22	16	12	SK-12-1A	120	2
KGP-16-1	100	113	18	24	26	25	16	12	SK-16-1A	160	2.43
KGP-16-2	80	109	19	20	26	25	16	12	SK-16-1A	160	2
KGP-21-2	100	118	14	24	29	28	16	12	SK-21-1A	210	3

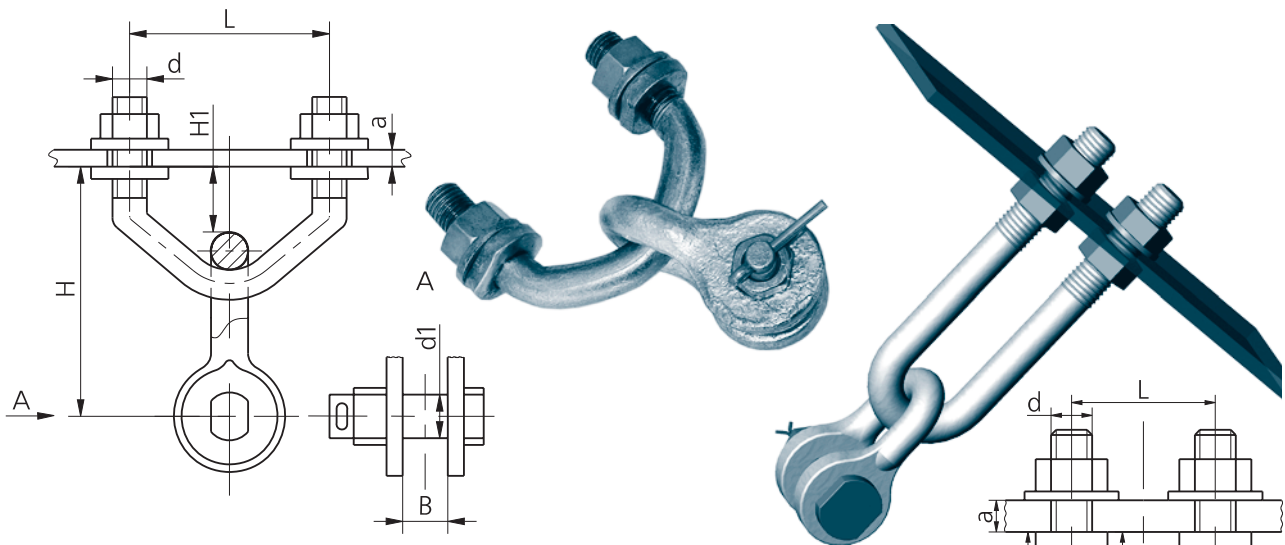

Attachment joints of KGP type (incorporating a shackle)

Attachment joints of KGP type are intended for fastening suspension insulating strings to towers of overhead power lines and switchgears.

Dimensions of KGP type attachment joints comply with the relevant dimensions of towers.

Attachment joints meet TU 3449-108-0011120-94 requirements.

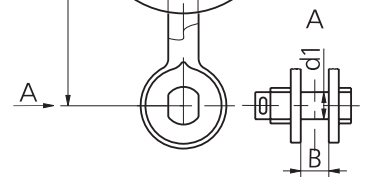

Reference уэла	Dimensions, mm								Reference designation of incorporated shackle	Minimum failing load, kN	Weight, kg
	L	H	H1	d	B	d1	a _{max}	a _{min}			
KGP-7-1A	60	134	70	16	17	16	8	6	SK-7-1A	70	0.98
KGP-7-1B	50	169	105	16	17	16	8	6	SK-7-1A	70	1.1
KGP-12-1A	55	266	183	20	23	22	16	12	SK-12-1A	120	2.55
KGP-9/12-2S	44	95	12	20	23	22	18	12	SK-12-1A	120	1.7

Attachment joint of KGT-7-1 type

Attachment joint of KGT-7-1 type is intended for fastening suspension clamps of earthwires to wooden towers.

Minimum failing load – 70 kN. Weight – 3.7 kg.

Attachment joint meet TU 3449-108-0011120-94 requirements.

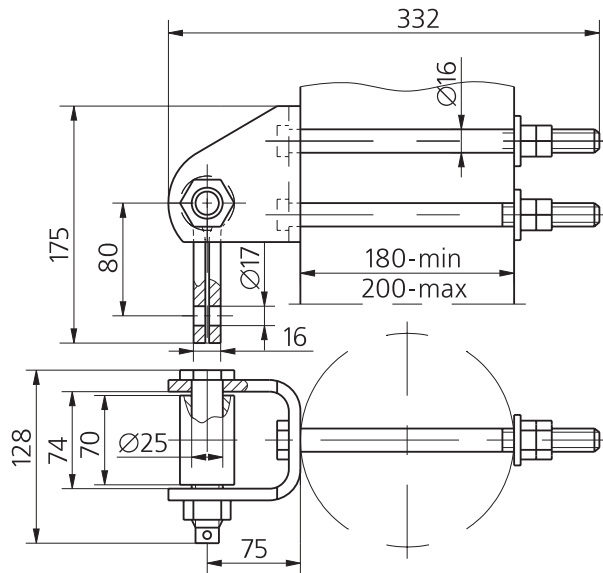

Attachment joint of KG-1 type

Attachment joint of KG-1 type is intended for fastening tension and suspension insulating strings.

Minimum failing load – 40 kN. Weight – 0.26 kg.

Attachment joint meet GOST R 51177-98 requirements.

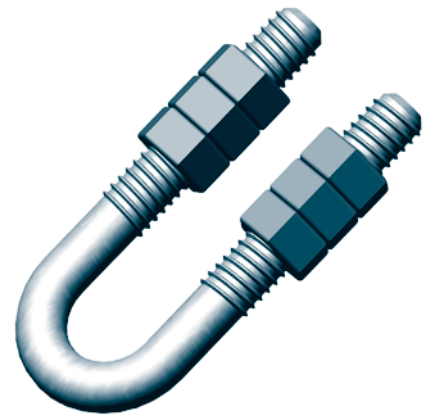
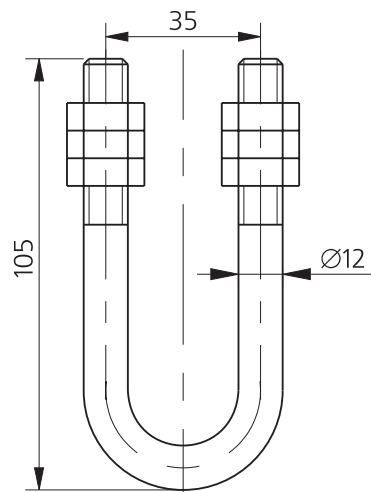

Attachment joints of KG type (incorporating a shackle)

Attachment joints of KG type are intended for fastening tension and suspension insulating strings to towers of overhead power lines and switchgears.

Attachment joints of KG type are fastened to towers by U-bolts.

After tightening the nuts are locked by centre-punching to prevent their loosening.

Attachment joints meet TU 3449-108-0011120-94 requirements.

Reference designation	Dimensions, mm					Reference designation of incorporated shackle	Minimum failing load, kN	Weight, kg
	L	H	H1	d	l			
KG-12-1	85	92	—	16	41	SK-12-1A	120	2.11
KG-12-3	85	—	—	16	41	—	120	1.2
KG-16-1	95	99	9	20	48	SK-16-1A	160	3.22
KG-21-1	95	104	5	20	48	SK-21-1A	210	4.1
KG-21-3	95	—	—	20	48	—	210	2

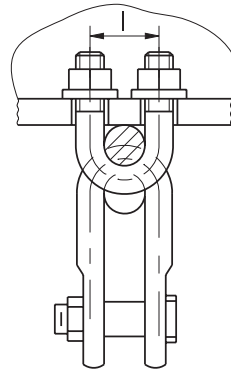
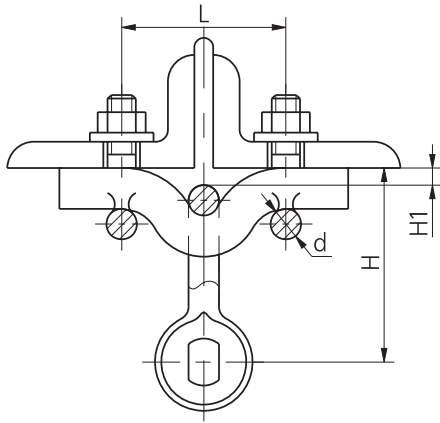

Attachment joints of KGN type

Attachment joints of KGN type are intended for fastening tension insulating strings to towers on special crossing spans with high mechanical ratings.

Attachment joints meet TU 3449-108-0011120-94 requirements.

Reference designation	Dimensions, mm						Minimum failing load, kN	Weight, kg
	B	L	H	H1	D	d		
KGN-7-5	16	60	120	105	17	32	70	3.07
KGN-12-5	22	70	160	140	23	40	120	5.2
KGN-16-5	25	70	160	140	26	40	160	5.22
KGN-21-5	28	85	180	160	29	50	210	10.1
KGN-30-5	36	100	200	180	38	56	300	15.6
KGN-45/30-1A	40	115	242	190	42	56	450	16
KGN-45-5	40	115	220	200	42	70	450	23.6
KGN-60-5	45	125	220	200	47	75	600	29
KGN-75-5	50	140	250	230	52	85	750	41.3
KGN-90-5	56	145	250	230	58	90	900	47.0

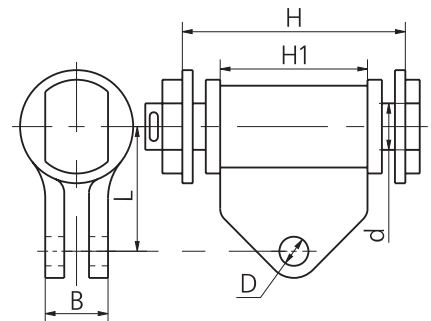
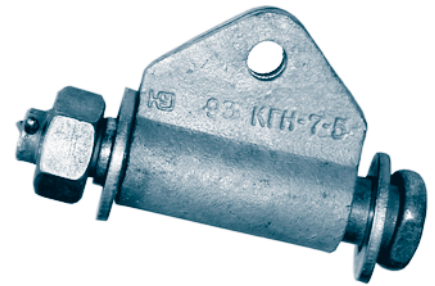

Suspension clamps of PG type

Suspension clamps of PG type are intended for fastening conductors and earthwires to insulating strings on intermediate and angle towers of overhead power lines. Suspension clamps meet TU 3449-126-00111120-97 requirements.

Reference designation	Dimensions, mm				Conductor or an earthwire	Minimum failing load, kN	Weight, kg
	L	l	H	h			
PG-1-11	240	86	190	112	Ø11, Ø13 earthwire	60	3.7
PG-3-10	300	88	215	128	Conductor: ACSR 70/72 ACSR 95/141 Earthwire with a cross-section of 276.34	60	5

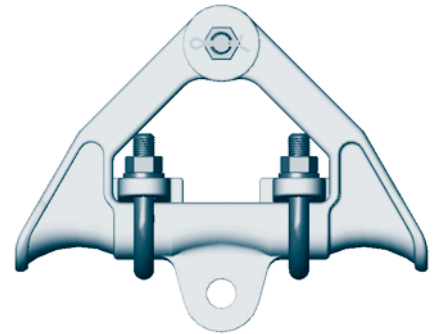
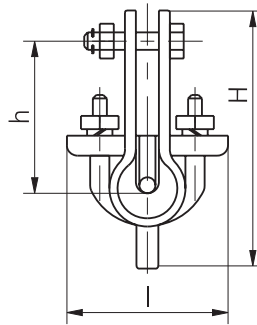
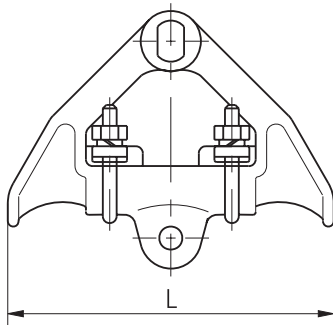

Suspension clamp of PG-1 type

Dead end suspension clamp of PG-1 type is intended for fastening 5.6 mm...11.4 mm diameter conductors and earthwires to insulating strings. Minimum failing load – 6 kN. Weight – 0.38 kg. Suspension clamp meet GOST R 51177-98 requirements.

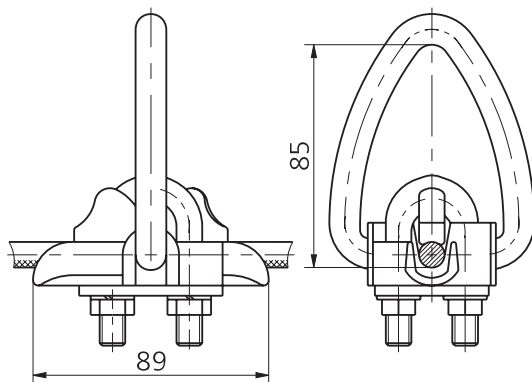

Suspension clamp of PB-3 type

Dead end suspension clamp of PB-3 type is intended for fastening 13.5 mm...19.8 mm diameter aluminium and steel-aluminium conductors to insulating strings.

Minimum failing load – 70 kN.

Weight – 1.4 kg.

Suspension clamp meet GOST R 51177-98 requirements.

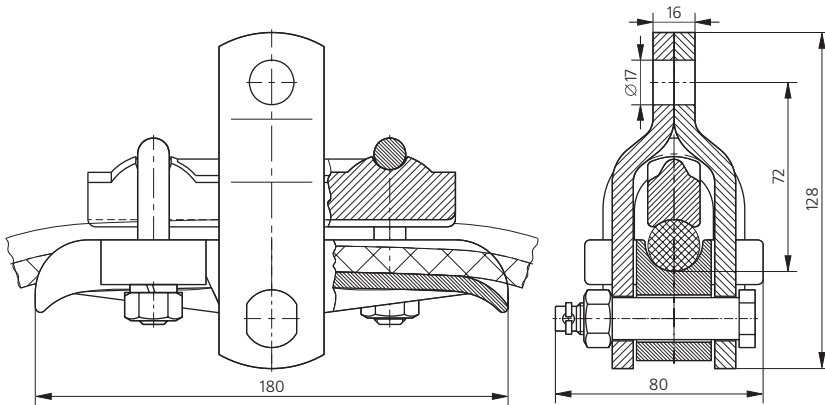

Advantages of suspension clamp of PB-3 type

1. Advanced physical characteristics of the clamp.
2. Basic assembly units of the clamp are made from steel-aluminum with the purpose to reduce the loss enhancement on alternating magnetization.

Suspension clamps of PGN-1-5, PGN-2-6 and PGN-3-5 type

Dead end suspension clamps of PGN-1-5, PGN-2-6, PGN-3-5 type are intended for fastening one conductor to insulating strings of 35, 110, 220 kV power lines. Suspension clamps meet TU 3449-126-00111120-97 requirements.

Reference designation	Dimensions, mm				Conductor diameter, mm	Minimum failing load, kN	Weight, kg
	L	H	h	b			
PGN-1-5	192	93	55	17	6.4...9.0	25	0.7
PGN-2-6	192	92	55	17	9.2...12.6	25	0.7
PGN-3-5	220	98	66	20	13.5...19.8	25	1.1

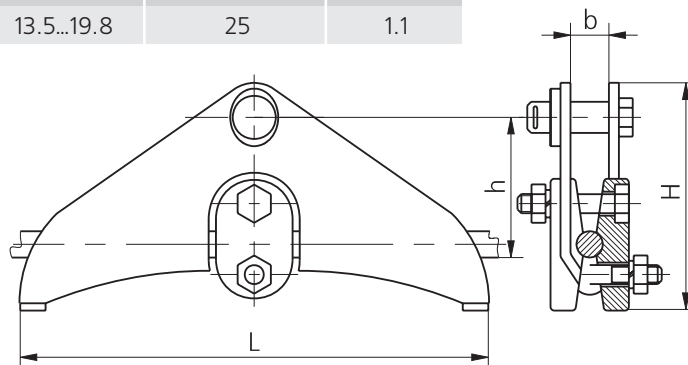
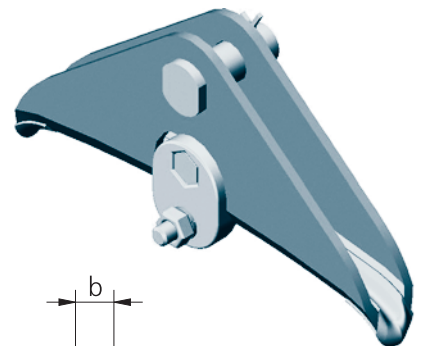

Suspension clamp of PGN-2-6A type

Dead end suspension clamp of PGN-2-6A type is intended for fastening one conductor to insulating strings of 35, 110, 220 kV power lines.
 Minimum failing load – 25 kN.
 Weight – 0.94 kg.
 Suspension clamp meet TU 3449-126-00111120-97 requirements.

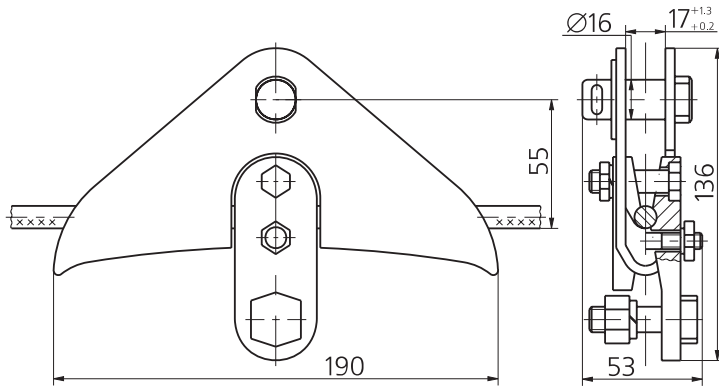

Suspension clamps of PGN-5-3, PGN-5-4 and PGN-6-5 type

Dead end suspension clamps of PGN-5-3, PGN-5-4 and PGN-6-5 type are intended for fastening one conductor to insulating strings on intermediate and angle towers of overhead power lines.
 Suspension clamps meet TU 3449-126-00111120-97 requirements.

Reference designation	Dimensions, mm					Conductor diameter, mm	Minimum failing load, kN	Weight, kg
	L	H	h	B	b			
PGN-5-3	290	160	190	–	19.2	21.6...33.2	60	5.5
PGN-5-4	300	162	196	–	19.2	21.6...33.2	100	7.1
PGN-6-5	300	154	203	–	19.2	34.5...37.5	100	6.5



Clamp PGN-5-3, PGN-5-4 is completed with corresponded gasket. See page 59.

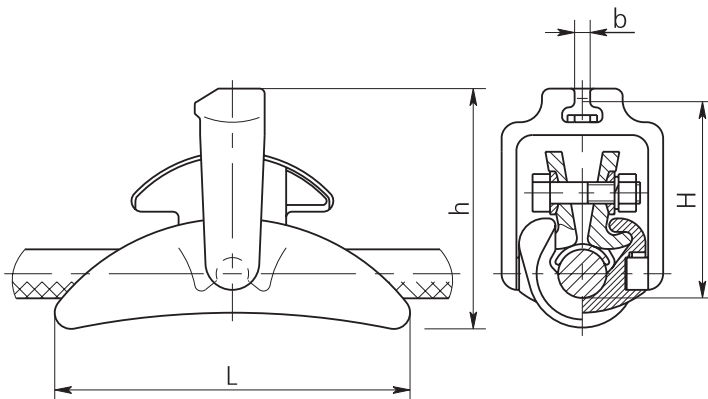

Suspension clamp of PGN-5-6 type

Dead end suspension clamp of PGN-5-6 type is intended for fastening one conductor to insulating strings on intermediate and angle towers of overhead power lines.

Suspension clamp meet TU 3449-126-00111120-97 requirements.



Reference designation	Dimensions, mm					Conductor diameter, mm	Minimum failing load, kN	Weight, kg
	L	H	h	B	b			
PGN-5-6	290	—	246	114	—	21.6...33.2	60	5.0

Clamp is completed with corresponded gasket. See page 59.

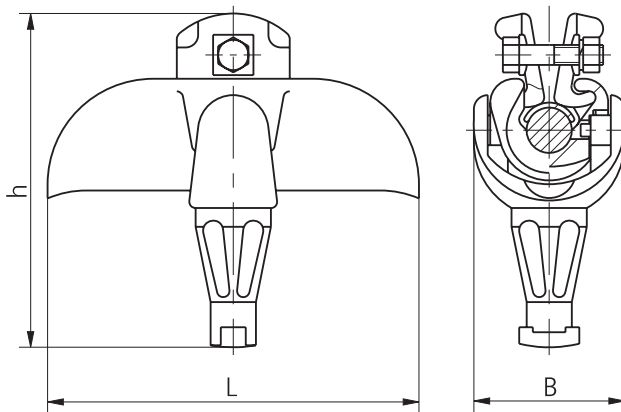

Suspension clamps with protective twisted cover of PGN-5-3PZ type

Suspension clamps of PGN-5-3PZ type are intended for fastening steel-aluminium conductors to intermediate and angle towers of overhead power lines.
 Minimum failing load – 60 kN.
 Suspension clamps meet TU 3449-126-0011120-97 requirements.

Reference designation	Dimensions, mm		Conductors with GOST 839-80		Weight, kg
	L	D1	Section, mm ²	Diameter D, mm	
PGN-5-3PZ-21.6	2200	30.0	240/32	21.6	6.7
			240/39		
PGN-5-3PZ-22.4	2300	30.8	240/56	22.4	6.9
PGN-5-3PZ-24.0		31.2	300/39	24.0	
		31.3	300/48	24.1	
PGN-5-3PZ-24.5	2300	31.7	300/67	24.5	7.1
PGN-5-3PZ-24.8		32.0	330/30	24.8	
		32.4	330/43	25.2	

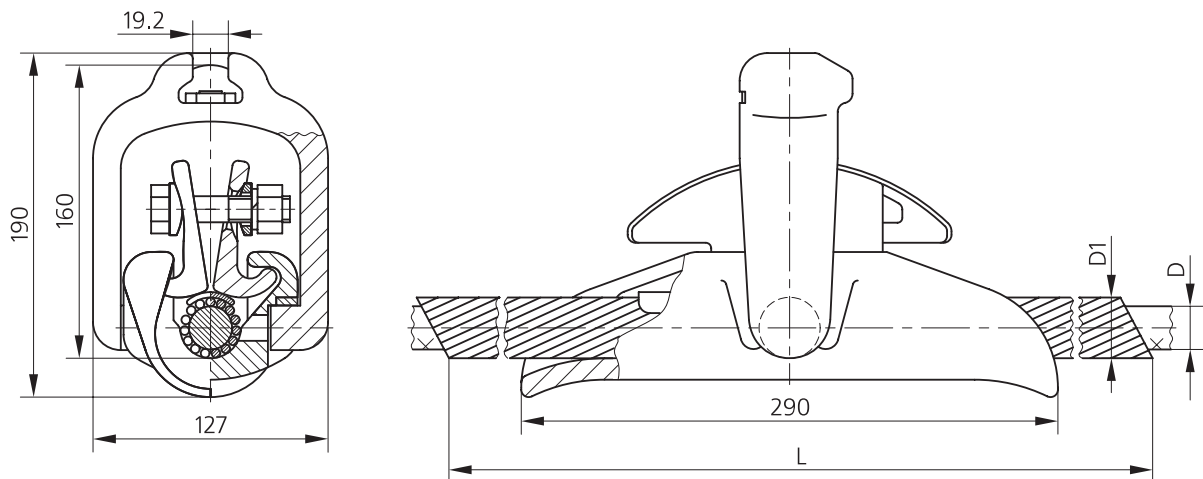

Suspension clamps with protective twisted cover of PGN-5-4PZ type

Suspension clamps of PGN-5-4PZ type are intended for fastening steel-aluminium conductors to intermediate and angle towers of overhead power lines.
 Minimum failing load – 100 kN.
 Suspension clamps meet TU 3449-126-0011120-97 requirements.

Reference designation	Dimensions, mm		Conductors with GOST 839-80		Weight, kg
	L	D1	Section, mm ²	Diameter D, mm	
PGN-5-4PZ-21.6	2200	30.0	240/32	21.6	8.4
			240/39		
PGN-5-4PZ-22.4		30.8	240/56	22.4	
PGN-5-4PZ-24.0	2300	31.2	300/39	24.0	
		31.3	300/48	24.1	
PGN-5-4PZ-24.5		31.7	300/67	24.5	
PGN-5-4PZ-24.8		32.0	330/30	24.8	8.6
		32.4	330/43	25.2	

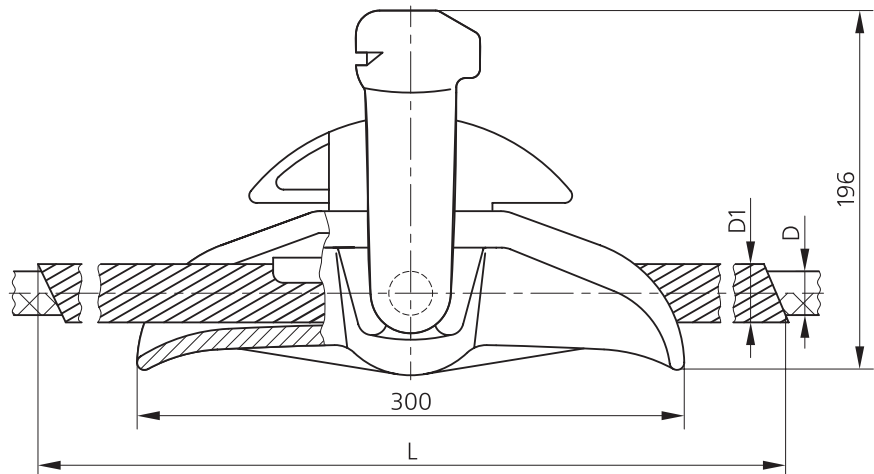
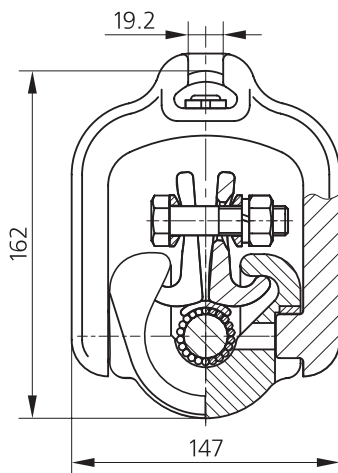

Dead end non-magnetic compensative suspension clamps for one conductor of PGN-5-12K type

Dead end suspension clamps of PGN-5-12K type are intended for fastening one conductor to the insulating strings of intermediate and angle suspension towers of transmission lines.

The following types of conductors are applied: A, AC according to GOST 839-80 and AAAC-Z according to TU 3510-001-699 48333.

Reference designation	Conductor of AAAC-Z according to TU 3510-001-699 48333	Nominal cross-section area of the conductors according to GOST 839-80, mm ²		Conductor diameter, mm	Conductor dressing strength, kN, not less than	Breaking load, kN, not less than	Weight, kg	Minimum failing load, kN
		A	AC					
PGN-5-12K0	—	—	500/64	30.6	29.65	148.26	2.4	100
		—	500/26	30.0	22.51	112.55		
		550	—	30.3	17.95	89.76		
PGN-5-12K1	—	—	450/56	28.8	26.27	131.37	2.46	
		—	500/27	29.4	22.44	112.19		
		—	400/93	29.1	34.74	173.72		
		—	300/204	29.2	56.92	284.58		
		500	—	29.1	16	80.00		
PGN-5-12K2	—	—	400/22	26.6	19.02	95.12	2.52	
		—	400/51	27.5	24.10	120.48		
		—	400/64	27.7	25.84	129.18		
		450	—	27.3	14.37	71.86		
	455-2Z	—	—	26.1	30.01	150.06		
PGN-5-12K3	—	—	330/43	25.2	20.76	103.78	2.58	
		—	400/18	26.0	17.12	85.6		
		400	—	25.6	12.68	63.42		
PGN-5-12K4	—	—	300/39	24.0	18.12	90.57	2.64	
		—	330/30	24.8	17.77	88.85		
		—	300/48	24.1	20.13	100.62		
		—	300/66	24.5	23.5	117.52		
		—	185/128	23.1	36.76	183.82		
		—	300/67	24.5	25.25	126.27		
		350	—	24.2	11.41	57.06		
PGN-5-12K5	—	—	240/32	21.6	15.01	75.05	2.7	
		—	240/39	21.6	16.18	80.9		
		—	240/56	22.4	19.65	98.25		
		300	—	22.1	9.51	47.57		

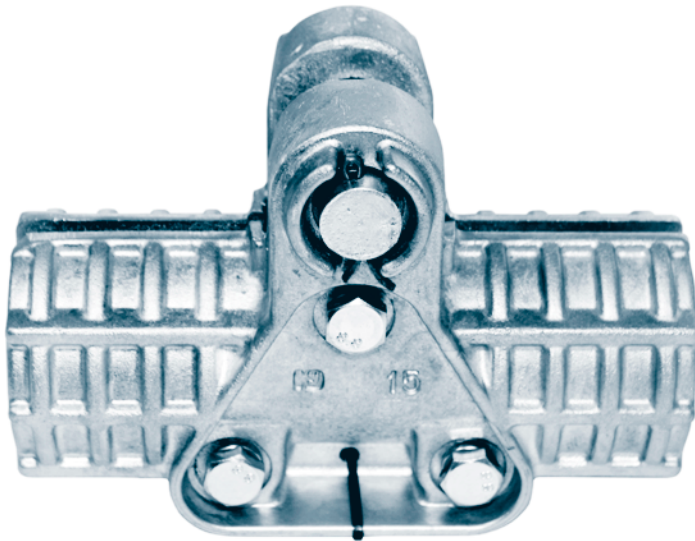
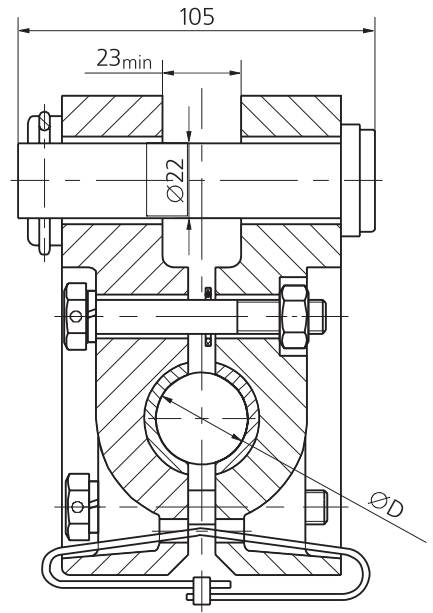
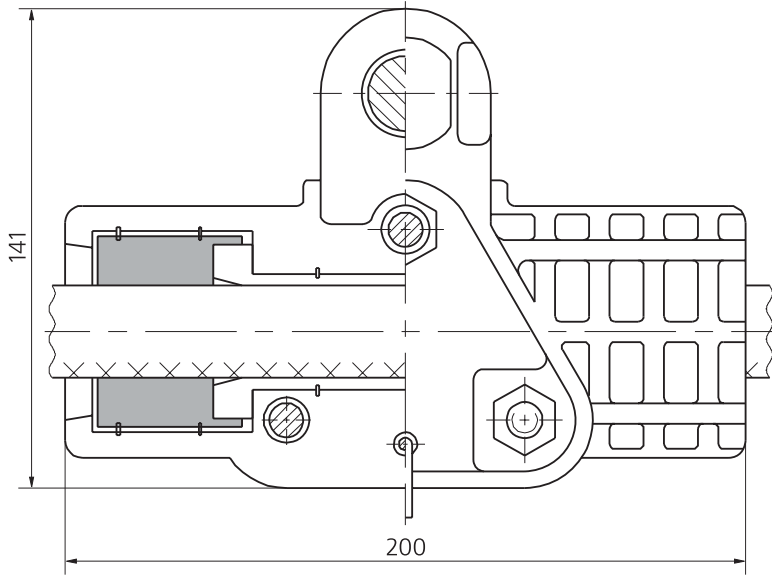

Suspension clamps with protective twisted cover of PGN-6-5PZ type

Suspension clamps of PGN-5-6PZ type are intended for fastening steel-aluminium conductors to intermediate and angle towers of overhead power lines.

Minimum failing load – 100 kN.

Suspension clamps meet TU 3449-126-0011120-97 requirements.

Reference designation	Dimensions, mm		Conductors with GOST 839-80		Weight, kg
	L	D1	Section, mm ²	Diameter D, mm	
PGN-6-5PZ-26.0	2300	36.6	400/18	26.0	9.1
		37.2	400/22	26.6	
PGN-6-5PZ-27.5		36.9	400/51	27.5	8.9

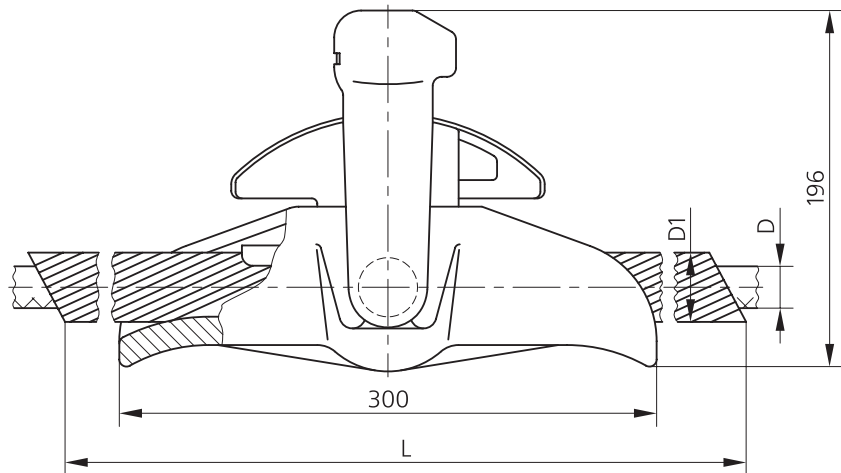
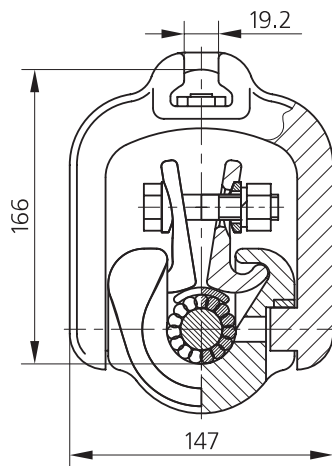

Suspension clamp of PGN2-5-A type intended for 21.6 mm...33.2 mm diameter conductor

Suspension clamp of PGN2-5-A type is intended for fastening one conductor to insulating strings on intermediate towers of overhead power lines.

Minimum failing load – 70 kN.

Weight – 9.32 kg.

Suspension clamp meet TU 3449-207-76935199-2007 requirements.

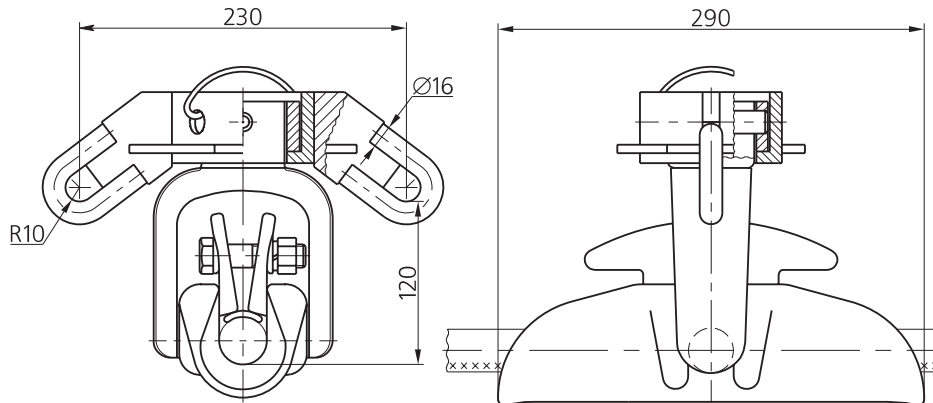

Clamp is completed with corresponded gasket. See page 59.

Suspension clamp of 2PGN-5-1 type intended for 21.6 mm...30.2 mm diameter conductors

Suspension clamp of 2PGN-5-1 type is intended for fastening two conductors (aluminium, steel-aluminium, copper) to intermediate and angle towers of overhead power lines.

Minimum failing load – 60 kN.

Weight – 5.0 kg.

Suspension clamp meet TU 3449-126-00111120-97 requirements.

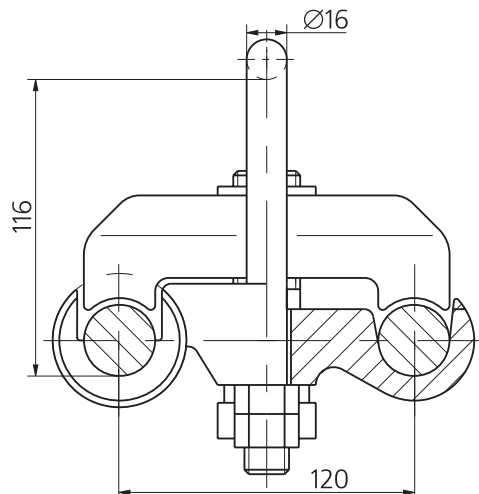

Suspension clamp of 2PGN-5-A type intended for 21.6 mm...33.2 mm diameter conductors

Suspension clamp of 2PGN-5-A type is intended for fastening two conductors to insulating strings on intermediate towers of overhead power lines.
 Minimum failing load – 120 kN.
 Weight – 30.41 kg.
 Suspension clamp meet TU 3449-207-76935199-2007 requirements.

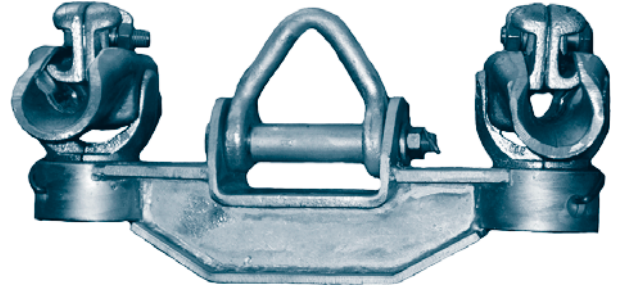

Clamp is completed with corresponded gasket. See page 59.

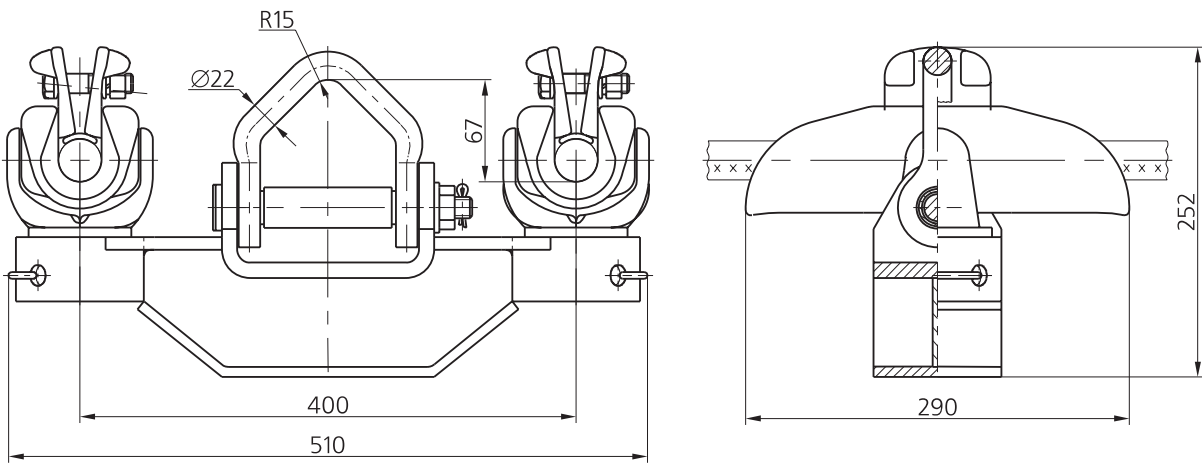

Suspension clamp of 2PGN-5-7 type intended for 21.6 mm...33.2 mm diameter conductors

Dead end suspension clamp of 2PGN-5-7 type is intended for fastening two conductors (aluminium, steel-aluminium, copper) to intermediate and angle towers of overhead power lines.
 Minimum failing load – 120 kN.
 Weight – 19.2 kg.
 Suspension clamp meet TU 3449-126-00111120-97 requirements.

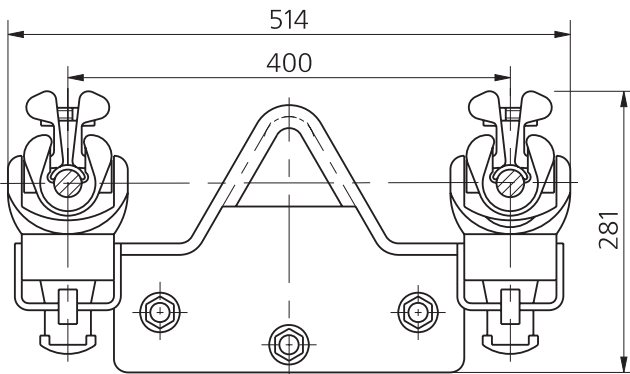
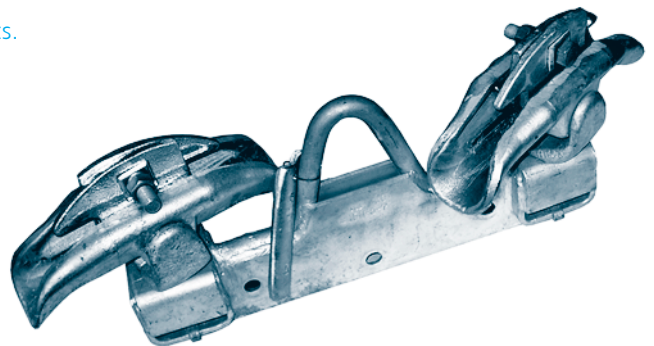

Clamp is completed with corresponded gasket. See page 59.

Suspension clamps with protective twisted cover of 2PGN-5-7PZ type

Dead end suspension clamps of 2PGN-5-7PZ type are intended for fastening two steel-aluminium conductors to intermediate and angle towers of overhead power lines.

Minimum failing load – 120 kN.

Suspension clamps meet TU 3449-126-00111120-97 requirements.

Reference designation	Dimensions, mm		Conductors with GOST 839-80		Weight, kg
	L	D1	Section, mm ²	Diameter D, mm	
2PGN-5-7PZ-21.6	2200	30.0	240/32	21.6	20.6
240/39					
2PGN-5-7PZ-22.4	2300	30.8	240/56	22.4	20.2
2PGN-5-7PZ-24.0		31.2	300/39	24.0	21.6
2PGN-5-7PZ-24.5	31.3	300/48	24.1		
2PGN-5-7PZ-24.8	2300	31.7	300/67	24.5	21.8
2PGN-5-7PZ-24.8		32.0	330/30	24.8	
		32.4	330/43	25.2	

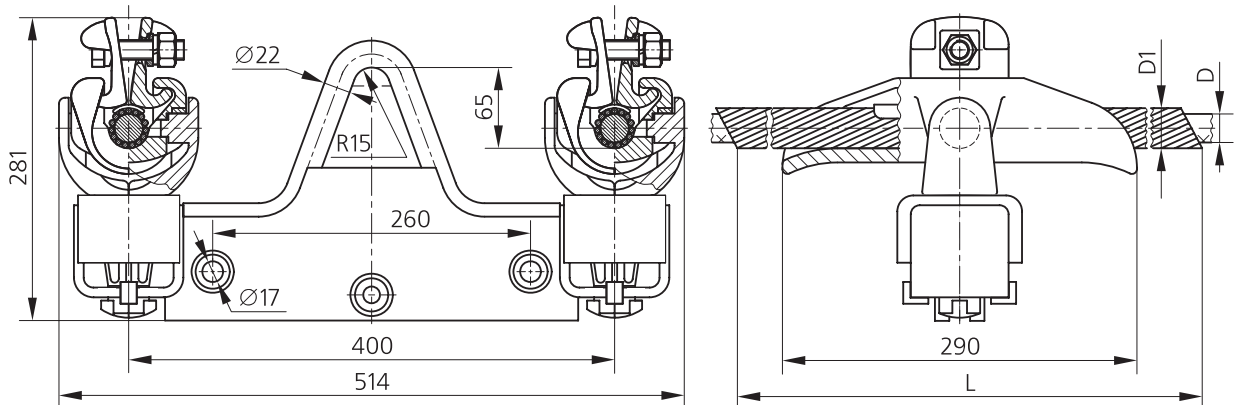

Dead end non-magnetic compensative suspension clamps for two conductors of 2PGN-5-12K type

Dead end suspension clamps of 2PGN-5-12K type are intended for fastening two conductors to the insulating strings of intermediate and angle suspension towers of transmission lines.

The following types of conductors are applied: A, AC according to GOST 839-80 and AAAC-Z according to TU 3510-001-699 48333.

Minimum failing load – not less than 200 kN.

Suspension clamps meet TU 3449-282-76935199-2015 requirements.

Reference designation	Nominal section of conductor, mm ²		Conductor diameter, mm	Breaking load, kN, not less than	Conductor dressing strength, kN, not less than	
	AAAC-Z455-2Z according to TU 3510-001-699 48333	According to GOST 839-80				
		A, AKP				AC, ACKC, ACKP, ACK
2PGN-5-12K0	–	–	500/64	30.6	148.26	29.652
		–	500/26	30.0	112.55	22.51
		550	–	30.3	89.76	17.952
2PGN-5-12K1	–	–	450/56	28.8	131.37	26.274
		–	500/27	29.4	112.19	22.438
		–	400/93	29.1	173.72	34.744
		–	300/204	29.2	284.58	56.916
		500	–	29.1	80.00	16.0
		–	–	–	–	–
2PGN-5-12K2	–	–	400/22	26.6	95.12	19.024
		–	400/51	27.5	120.48	24.096
		–	400/64	27.7	129.18	25.836
		450	–	27.3	71.86	14.372
	462	–	–	26.1	150.06	30.012
2PGN-5-12K3	–	–	330/43	25.2	103.78	20.756
		–	400/18	26.0	85.6	17.12
		400	–	25.6	63.42	12.684
2PGN-5-12K4	–	–	300/39	24.0	90.57	18.114
		–	330/30	24.8	88.85	17.77
		–	300/48	24.1	100.62	20.124
		–	300/66	24.5	117.52	23.504
		–	185/128	23.1	183.82	36.764
		–	300/67	24.5	126.27	25.254
		350	–	24.2	57.06	11.412
2PGN-5-12K5	–	–	240/32	21.6	75.05	15.01
		–	240/39	21.6	80.9	16.18
		–	240/56	22.4	98.25	19.65
		300	–	22.1	47.57	9.514

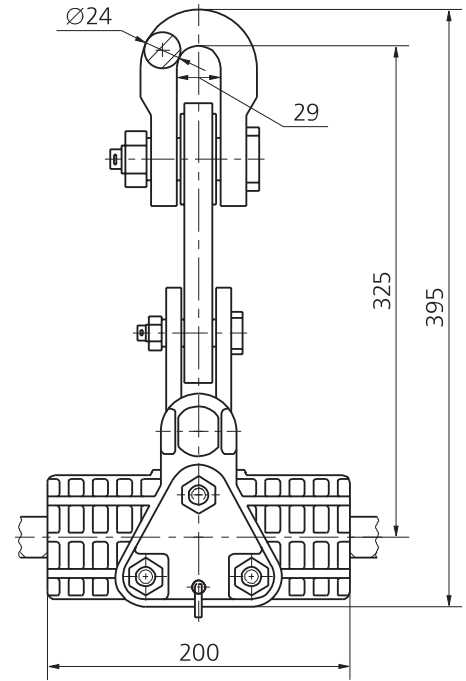
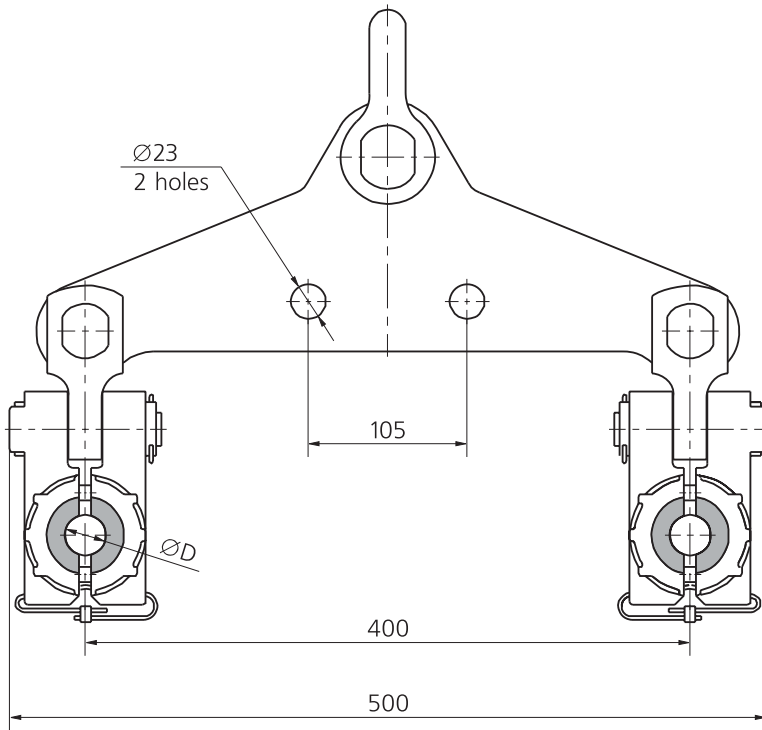

Suspension clamp of 2PGN2-5-A type intended for 21.6 mm...33.2 mm diameter conductors

Suspension clamp of 2PGN2-5-A type is intended for fastening two conductors to insulating strings on intermediate towers of overhead power lines.

Minimum failing load – 120 kN.

Weight – 19.3 kg.

Suspension clamp meet TU 3449-207-76935199-2007 requirements.

Clamp is completed with corresponded gasket. See page 59.

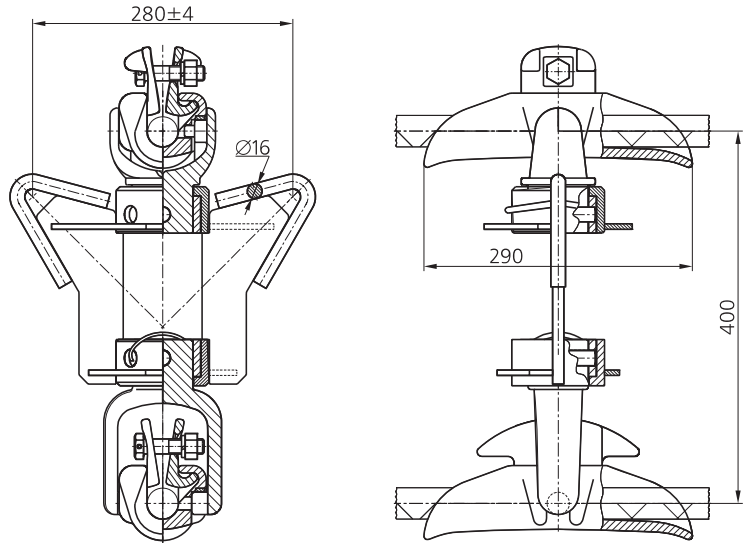

Suspension clamp of 3PGN-5-7 type intended for 21.6 mm...33.2 mm diameter conductors

Dead end suspension clamp of 3PGN-5-7 type is intended for fastening three conductors (aluminium, steel-aluminium, copper) to intermediate and angle towers of overhead power lines.

Minimum failing load – 180 kN.

Weight – 25.0 kg.

Suspension clamp meet TU 3449-126-00111120-97 requirements.

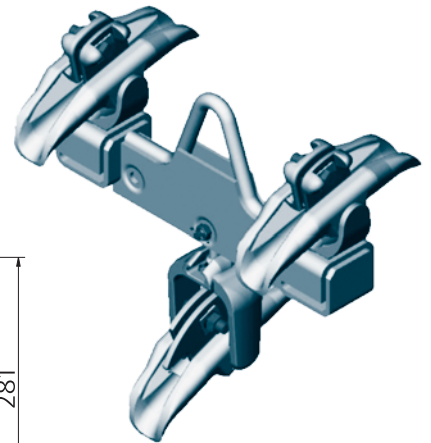
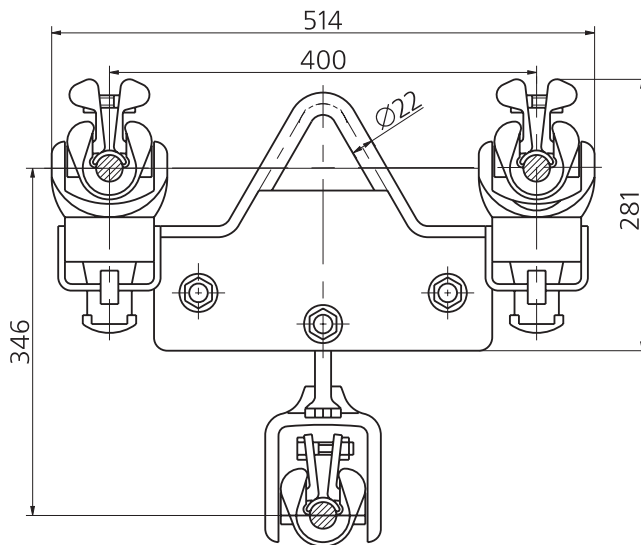

Clamp is completed with corresponded gasket. See page 59.

Suspension clamps with protective twisted cover of 3PGN-5-7PZ type

Dead end suspension clamps of 3PGN-5-7PZ type are intended for fastening three steel-aluminium conductors to intermediate and angle towers of overhead power lines.

Minimum failing load – 180 kN.

Suspension clamps meet TU 3449-126-00111120-97 requirements.

Reference designation	Dimensions, mm		Conductors with GOST 839-80		Weight, kg	
	L	D1	Section, mm ²	Diameter D, mm		
3PGN-5-7PZ-21.6	2200	30.0	240/32	21.6	26.4	
			240/39			
3PGN-5-7PZ-21.6-01	1200		240/32			24.5
			240/39			
3PGN-5-7PZ-22.4	2200	31.8	240/56	22.4	25.6	
3PGN-5-7PZ-22.4-01	1200				23.7	
3PGN-5-7PZ-24.0	2300	31.2	300/39	24.0	27.4	
		31.3	300/48	24.1		
3PGN-5-7PZ-24.0-01	1200	31.2	300/39	24.0	25.4	
		31.3	300/48	24.1		
3PGN-5-7PZ-24.5	2300	31.7	300/67	24.5	27.4	
3PGN-5-7PZ-24.5-01	1200				25.4	
3PGN-5-7PZ-24.8	2300	32.0	330/30	24.8	27.6	
		32.4	330/43	25.2		
3PGN-5-7PZ-24.8-01	1200	32.0	330/30	24.8	25.6	
		32.4	330/43	25.2		

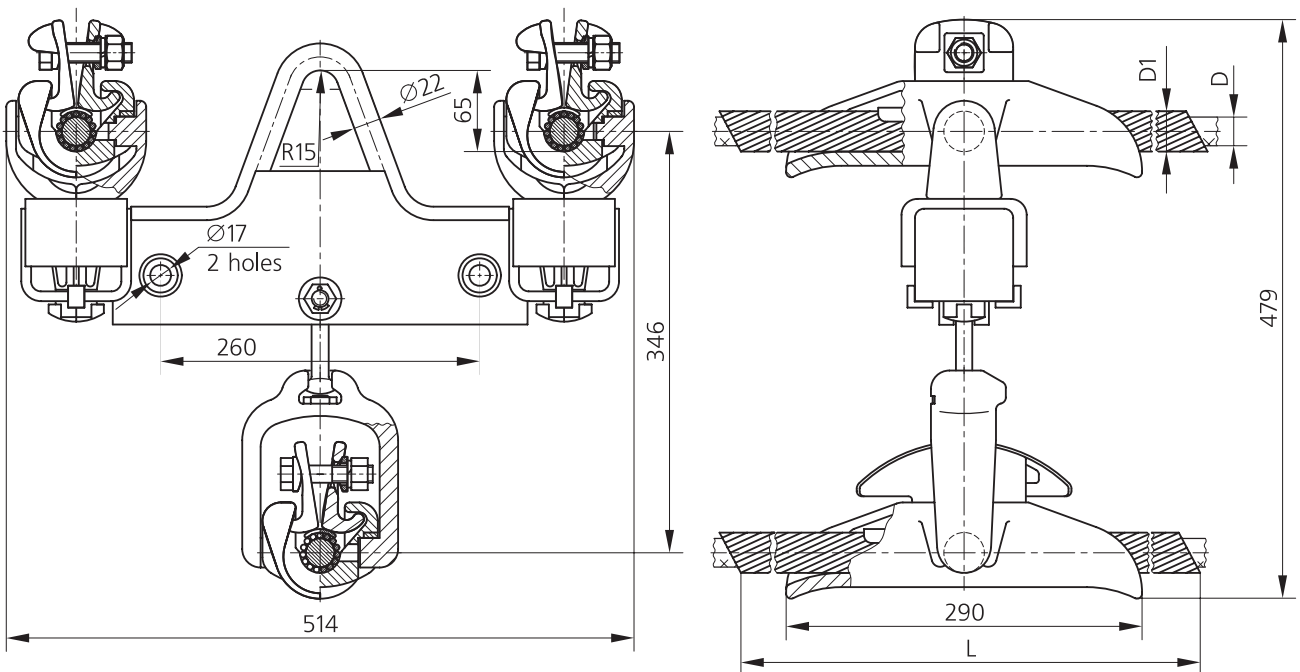

**Suspension clamp of 3PGN-5-A type
intended for 21.6 mm...33.2 mm diameter conductors**

Suspension clamp of 3PGN-5-A type is intended for fastening three conductors to insulating strings on intermediate towers of overhead power lines.
Minimum failing load – 210 kN.
Weight – 34.53 kg.
Suspension clamp meet TU 3449-207-76935199-2007 requirements.

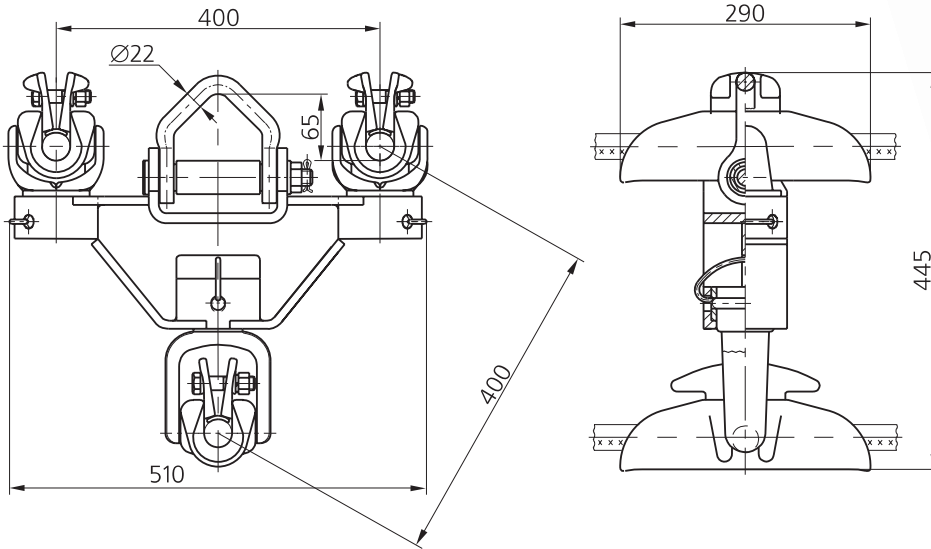
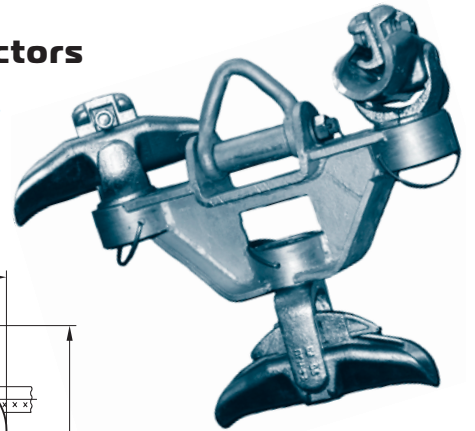

Clamp is completed with corresponded gasket. See page 59.

**Suspension clamp of 3PGN-5-12 type
intended for 21.6 mm...33.2 mm diameter conductors**

Dead end suspension clamp of 3PGN-5-12 type is intended for fastening three conductors (aluminium, steel-aluminium, copper) to insulating strings on intermediate towers of overhead power lines.
Minimum failing load – 300 kN.
Weight – 33.0 kg.
Suspension clamp meet GOST R 51177-98 requirements.

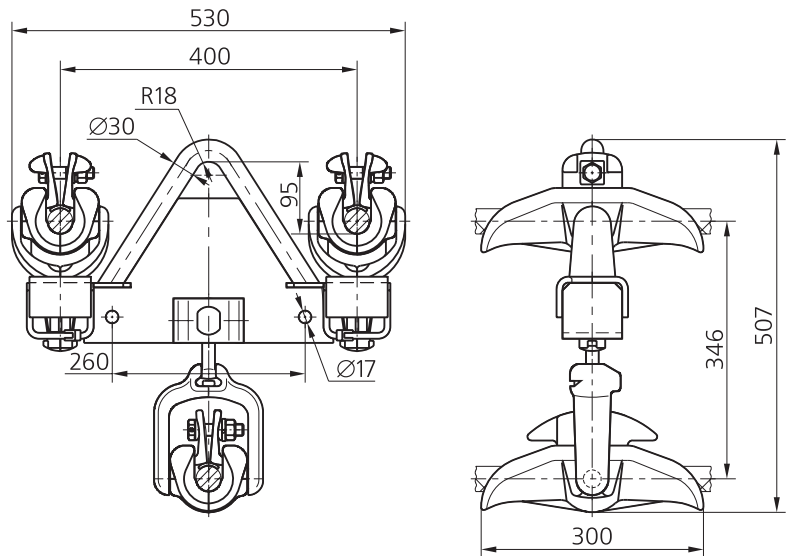
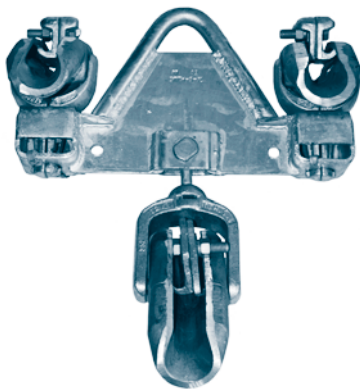

Clamp is completed with corresponded gasket. See page 59.

Suspension clamps with protective twisted cover of 3PGN-5-12PZ type

Dead end suspension clamps of 3PGN-5-12PZ type are intended for fastening three steel-aluminium conductors to intermediate and angle towers of overhead power lines.

Minimum failing load – 300 kN.

Suspension clamps meet TU 3449-126-00111120-97 requirements.

Reference designation	Dimensions, mm		Conductors with GOST 839-80		Weight, kg
	L	D1	Section, mm ²	Diameter D, mm	
3PGN-5-12PZ-21.6	2200	30.0	240/32	21.6	34.5
			240/39		
3PGN-5-12PZ-21.6-01	1200		240/32		
			240/39		
3PGN-5-12PZ-22.4	2200	31.8	240/56	22.4	34.0
3PGN-5-12PZ-22.4-01	1200				
3PGN-5-12PZ-24.0	2300	31.2	300/39	24.0	34.0
		31.3	300/48	24.1	
3PGN-5-12PZ-24.0-01	1200	31.2	300/39	24.0	32.0
		31.3	300/48	24.1	
3PGN-5-12PZ-24.5	2300	31.7	300/67	24.5	34.0
3PGN-5-12PZ-24.5-01	1200				
3PGN-5-12PZ-24.8	2300	32.0	330/30	24.8	34.0
		32.4	330/43	25.2	
3PGN-5-12PZ-24.8-01	1200	32.0	330/30	24.8	32.0
		32.4	330/43	25.2	

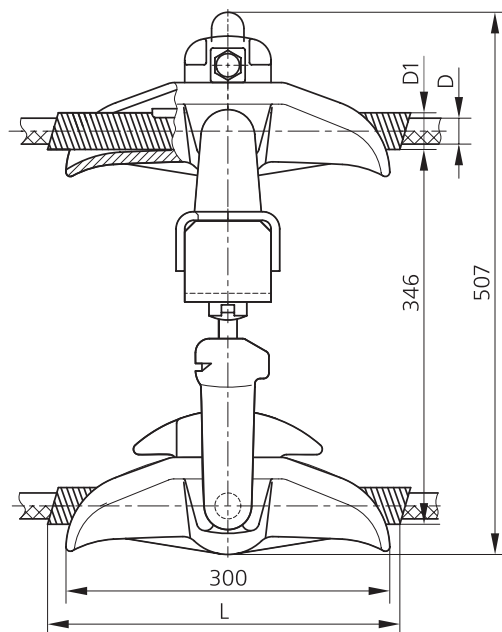
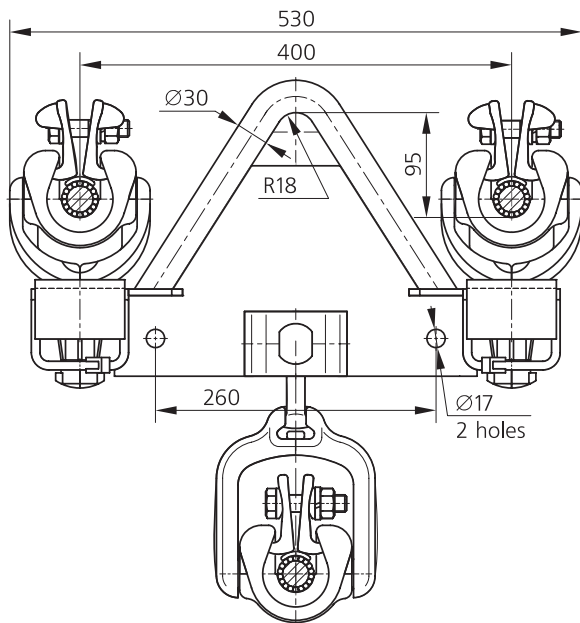

Dead end non-magnetic compensative suspension clamps for three conductors of 3PGN-5-12K type

Dead end suspension clamps of 3PGN-5-12K type are intended for fastening three conductors to the insulating strings of intermediate and angle suspension towers of transmission lines.

The following types of conductors are applied: A, AC according to GOST 839-80 and AAAC-Z according to TU 3510-001-699 48333.

Minimum failing load – not less than 300 kN.

Suspension clamps meet TU 3449-282-76935199-2015 requirements.

Reference designation	Nominal section of conductor, mm ²		Conductor diameter, mm	Breaking load, kN, not less than	Conductor dressing strength, kN, not less than	
	AAAC-Z455-2Z according to TU 3510-001-699 48333	According to GOST 839-80				
		A, AKP				AC, ACKC, ACKP, ACK
3PGN-5-12K0	–	–	500/64	30.6	148.26	29.652
		–	500/26	30.0	112.55	22.51
		550	–	30.3	89.76	17.952
3PGN-5-12K1	–	–	450/56	28.8	131.37	26.274
		–	500/27	29.4	112.19	22.438
		–	400/93	29.1	173.72	34.744
		–	300/204	29.2	284.58	56.916
		500	–	29.1	80.00	16.0
		–	–	–	–	–
3PGN-5-12K2	–	–	400/22	26.6	95.12	19.024
		–	400/51	27.5	120.48	24.096
		–	400/64	27.7	129.18	25.836
		450	–	27.3	71.86	14.372
	462	–	–	26.1	150.06	30.012
3PGN-5-12K3	–	–	330/43	25.2	103.78	20.756
		–	400/18	26.0	85.6	17.12
		400	–	25.6	63.42	12.684
3PGN-5-12K4	–	–	300/39	24.0	90.57	18.114
		–	330/30	24.8	88.85	17.77
		–	300/48	24.1	100.62	20.124
		–	300/66	24.5	117.52	23.504
		–	185/128	23.1	183.82	36.764
		–	300/67	24.5	126.27	25.254
		350	–	24.2	57.06	11.412
3PGN-5-12K5	–	–	240/32	21.6	75.05	15.01
		–	240/39	21.6	80.9	16.18
		–	240/56	22.4	98.25	19.65
		300	–	22.1	47.57	9.514

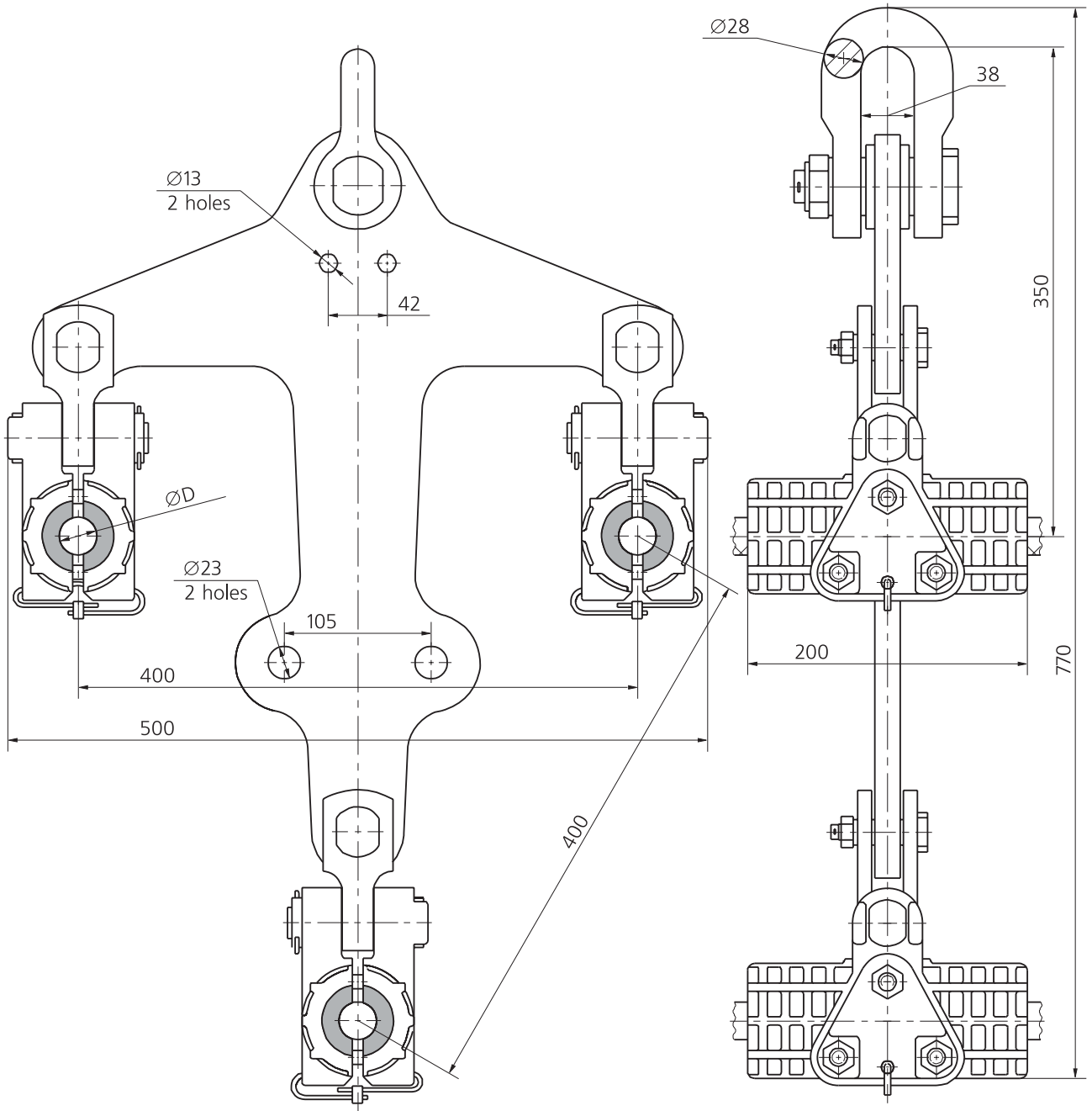

Suspension clamps with protective twisted cover of 3PGN-6-12PZ type

Dead end suspension clamps of 3PGN-6-12PZ type are intended for fastening three steel-aluminium conductors to intermediate and angle towers of overhead power lines.

Minimum failing load – 300 kN.

Suspension clamps meet TU 3449-126-00111120-97 requirements.

Reference designation	Dimensions, mm		Conductors with GOST 839-80		Weight, kg
	L	D1	Section, mm ²	Diameter D, mm	
3PGN-6-12PZ-26.0	2300	36.6	400/18	26.0	33.0
		37.2	400/22	26.6	
3PGN-6-12PZ-26.0-01	1200	36.6	400/18	26.0	29.7
		37.2	400/22	26.6	
3PGN-6-12PZ-27.5	2300	36.9	400/51	27.5	32.6
3PGN-6-12PZ-27.5-01	1200				

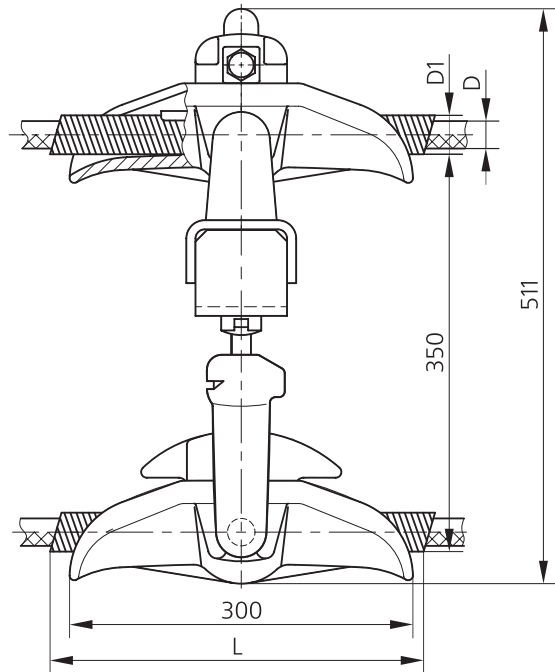
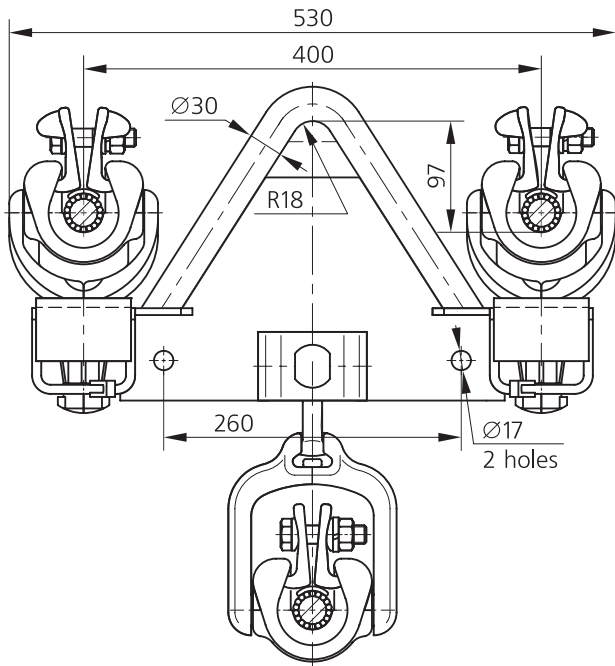

Suspension clamp of 3PGN2-5-A type intended for 21.6 mm...33.2 mm diameter conductors

Suspension clamp of 3PGN2-5-A type is intended for fastening three conductors to insulating strings on intermediate towers of overhead power lines.

Minimum failing load – 180 kN.

Weight – 33.11 kg.

Suspension clamp meet TU 3449-207-76935199-2007 requirements.

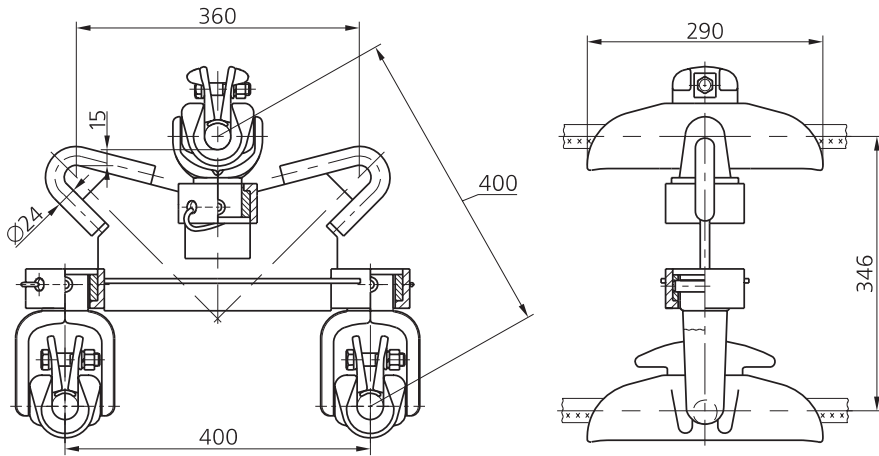

Clamp is completed with corresponded gasket. See page 59.

Dead end non-magnetic compensative suspension clamps for four conductors of 4PGN-5-12K type

Dead end suspension clamps of 4PGN-5-12K type are intended for fastening four conductors to the insulating strings of intermediate and angle suspension towers of transmission lines.

The following types of conductors are applied: A, AC according to GOST 839-80 and AAAC-Z according to TU 3510-001-699 48333.

Minimum failing load – not less than 210 kN.

Suspension clamps meet TU 3449-282-76935199-2015 requirements.

Reference designation	Nominal section of conductor, mm ²		Conductor diameter, mm	Link diameter D, mm	Breaking load, kN, not less than	Conductor dressing strength, kN, not less than	Weight, kg	
	AAAC-Z455-2Z according to TU 3510-001-699 48333	According to GOST 839-80						
		A, AKP						AC, ACKC, ACKP, ACK
4PGN-5-12K0	–	–	500/64	30.6	148.26	29.652	43.4	
		–	500/26	30.0	112.55	22.51		
		550	–	30.3	89.76	17.952		
4PGN-5-12K1	–	–	450/56	28.8	131.37	26.274	43.58	
		–	500/27	29.4	112.19	22.438		
		–	400/93	29.1	173.72	34.744		
		–	300/204	29.2	284.58	56.916		
		500	–	29.1	80.00	16.0		
		–	–	–	–	–		
4PGN-5-12K2	–	–	400/22	26.6	95.12	19.024	43.76	
		–	400/51	27.5	120.48	24.096		
		–	400/64	27.7	129.18	25.836		
		450	–	27.3	71.86	14.372		
	462	–	–	26.1	150.06	30.012		
4PGN-5-12K3	–	–	330/43	25.2	103.78	20.756	43.94	
		–	400/18	26.0	85.6	17.12		
		400	–	25.6	63.42	12.684		
4PGN-5-12K4	–	–	300/39	24.0	90.57	18.114	44.12	
		–	330/30	24.8	88.85	17.77		
		–	300/48	24.1	100.62	20.124		
		–	300/66	24.5	117.52	23.504		
		–	185/128	23.1	183.82	36.764		
		–	300/67	24.5	126.27	25.254		
		350	–	24.2	57.06	11.412		
4PGN-5-12K5	–	–	240/32	21.6	75.05	15.01	44.3	
		–	240/39	21.6	80.9	16.18		
		–	240/56	22.4	98.25	19.65		
		300	–	22.1	47.57	19.514		

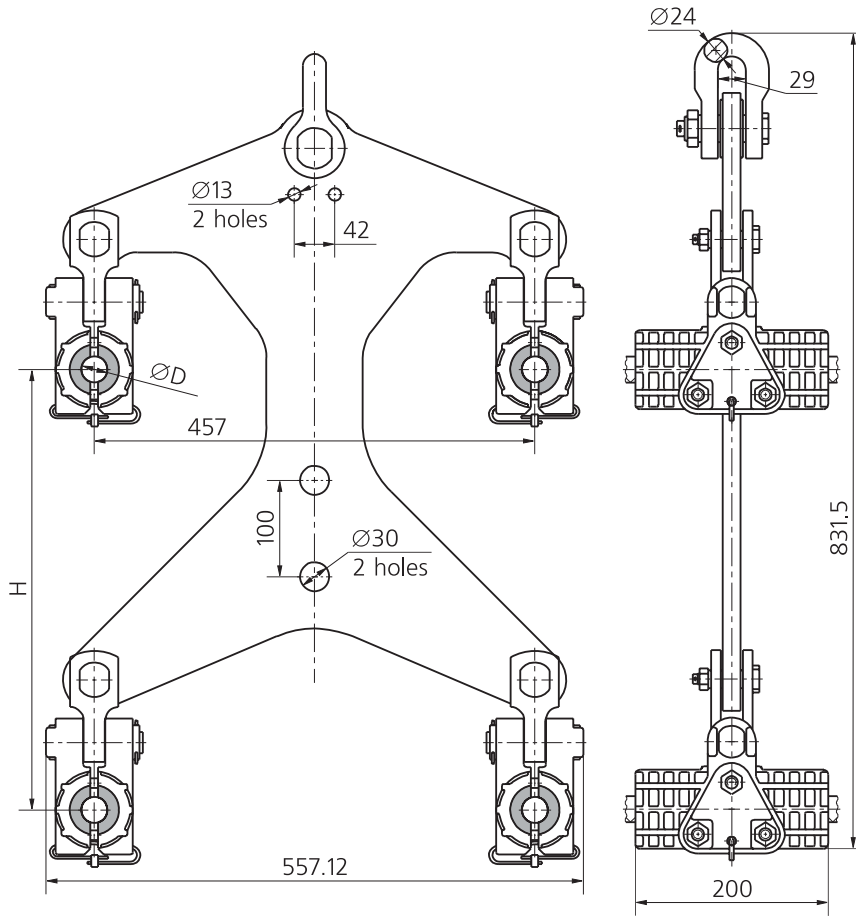

Dead end non-magnetic compensative suspension clamps for four conductors of 4PGN2-5-12K type

Dead end suspension clamps of 4PGN2-5-12K type are intended for fastening four phase conductors with two attachment point to the insulating strings of intermediate and angle suspension towers of transmission lines.

The following types of conductors are applied: A, AC according to GOST 839-80 and AAAC-Z according to TU 3510-001-699 48333.

Minimum failing load – not less than 400 kN.

Suspension clamps meet TU 3449-282-76935199-2015 requirements.

Reference designation	Nominal section of conductor, mm ²		Conductor diameter, mm	Link diameter D, mm	Breaking load, kN, not less than	Conductor dressing strength, kN, not less than	Weight, kg	
	AAAC-Z455-2Z according to TU 3510-001-699 48333	According to GOST 839-80						
		A, AKP						AC, ACKC, ACKP, ACK
4PGN2-5-12K0	–	–	500/64	30.6	148.26	29.652	46.3	
		–	500/26	30.0	112.55	22.51		
		550	–	30.3	89.76	17.952		
4PGN2-5-12K1	–	–	450/56	28.8	131.37	26.274	46.48	
		–	500/27	29.4	112.19	22.438		
		–	400/93	29.1	173.72	34.744		
		–	300/204	29.2	284.58	56.916		
		500	–	29.1	80.00	16.0		
4PGN2-5-12K2	–	–	400/22	26.6	95.12	19.024	46.66	
		–	400/51	27.5	120.48	24.096		
		–	400/64	27.7	129.18	25.836		
		450	–	27.3	71.86	14.372		
	462	–	–	26.1	150.06	30.012		
4PGN2-5-12K3	–	–	330/43	25.2	103.78	20.756	46.84	
		–	400/18	26.0	85.6	17.12		
		400	–	25.6	63.42	12.684		
4PGN2-5-12K4	–	–	300/39	24.0	90.57	18.114	47.02	
		–	330/30	24.8	88.85	17.77		
		–	300/48	24.1	100.62	20.124		
		–	300/66	24.5	117.52	23.504		
		–	185/128	23.1	183.82	36.764		
		–	300/67	24.5	126.27	25.254		
		350	–	24.2	57.06	11.412		
4PGN2-5-12K5	–	–	240/32	21.6	75.05	15.01	47.2	
		–	240/39	21.6	80.9	16.18		
		–	240/56	22.4	98.25	19.65		
		300	–	22.1	47.57	19.514		

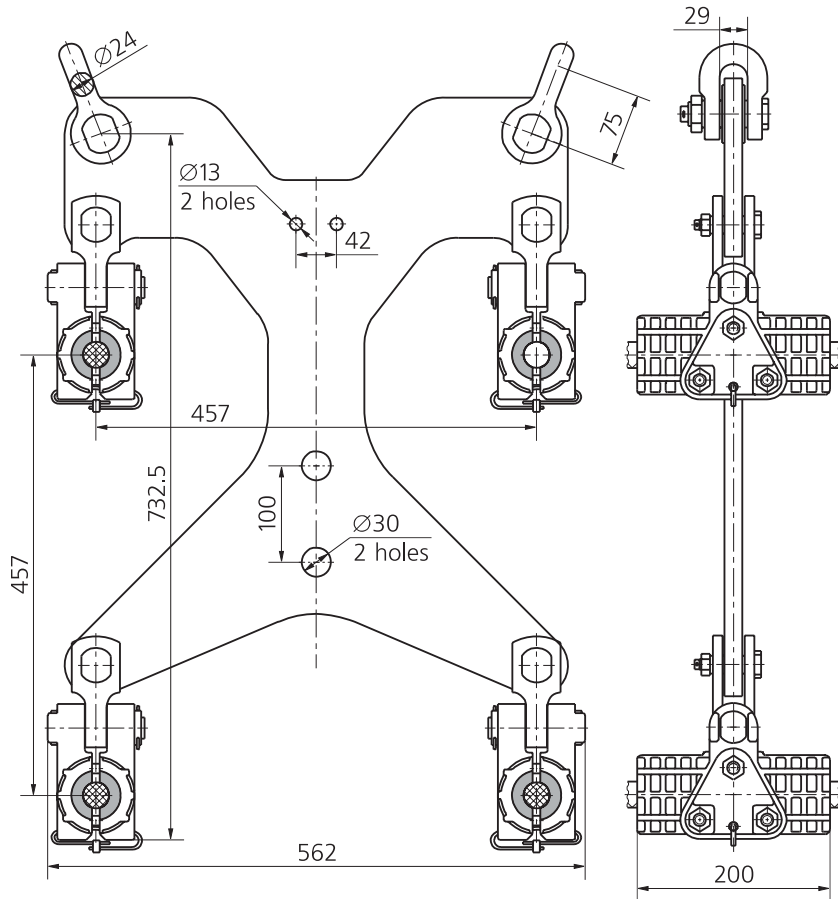

Suspension clamps of 5PGN-5-8 and 5PGN2-5-8 type

Suspension clamps of 5PGN-5-8, 5PGN2-5-8 type are intended for fastening five phase steel-aluminum conductors with one and two attachment point to the insulating string.

Suspension clamps meet TU 3449-126-0011120-97 requirements.

Reference designation	Conductor diameter, mm	Minimum failing load, kN	Weight, kg
5PGN-5-8	21.6...33.2	300	44.0
5PGN2-5-8	21.6...33.2	300	59.4

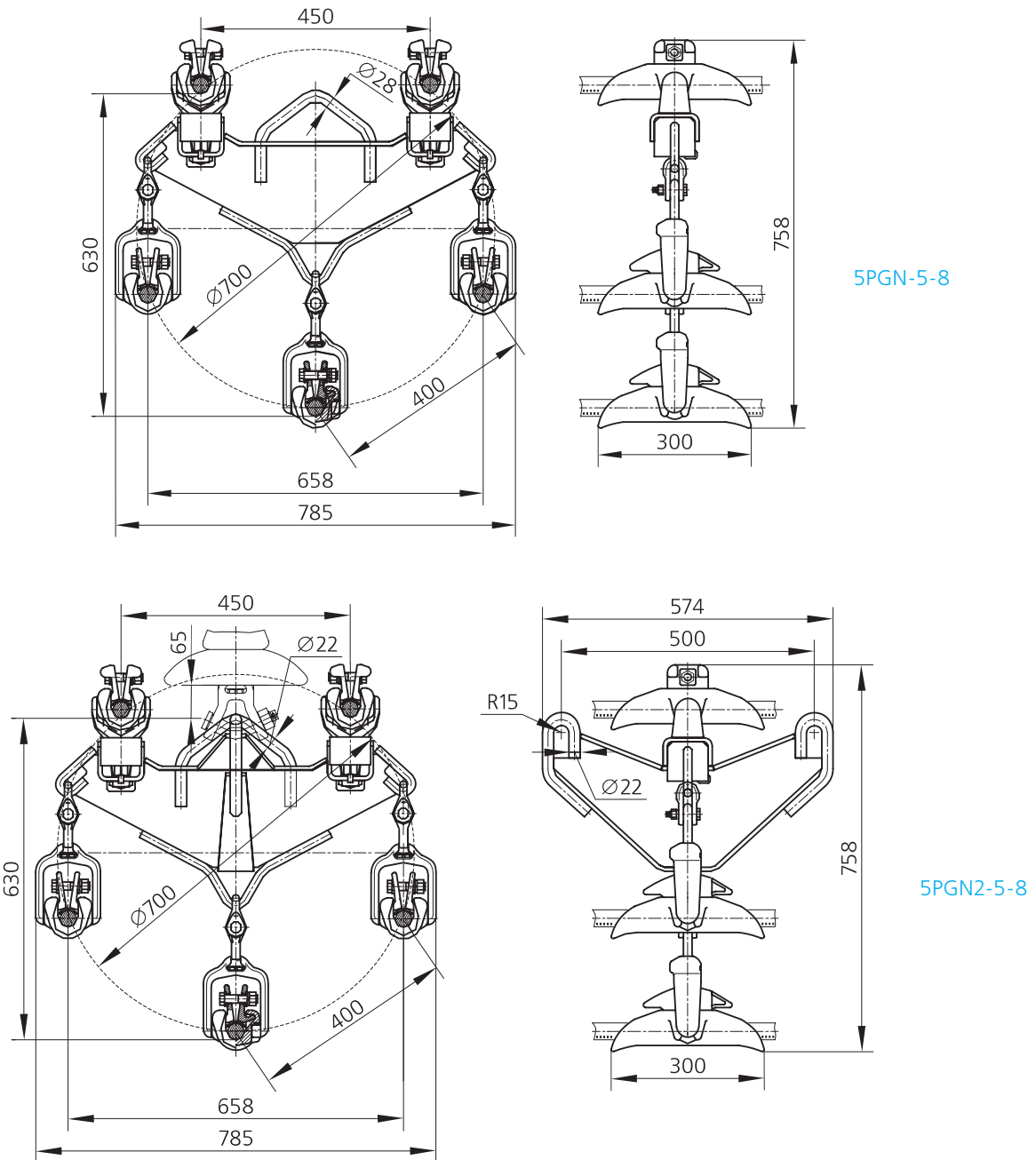

Suspension clamps PGN-5-3, PGN-5-4, PGN-5-6, PGN2-5-A, 2PGN-5-A, 2PGN-5-7, 2PGN2-5-A, 3PGN-5-7, 3PGN-5-A, 3PGN-5-12, 3PGN2-5-A, depends on conductors brand installed into the clamp, has to be completed by appropriate spacer.

Reference designation	Nominal cross section of conductor meet GOST, mm ²		Conductor diameter, mm
	A, AKP	AS, ASKS, ASKP, ASK	
A	650	550/71, 600/72	32.4...33.2
B	600	–	31.5
V	550	500/64	30.3...30.6
G	500	450/56, 500/27, 400/93, 300/204	28.8...29.4
D	450	400/22, 400/51, 400/64	26.6...27.7
E	400	330/43	25.2...25.6
J	350	300/39, 330/30, 300/48, 300/66, 185/128	23.1...24.8
K	300	240/32, 240/39, 240/56	21.6...22.4

Advantages of suspension clamp of PGN2-5-A, 2PGN-5-A, 2PGN2-5-A, 3PGN-5-A, 3PGN2-5-A type

Different from previous designs advanced physical characteristics, endurance, and rigidity dropper of a split conductor.

Suspension clamps of roller type for the long transitions

Suspension clamps of roller type for the long transitions are intended for fixing the steel/aluminium conductors and earthwires to the intermediate towers of the transmission lines in the crossing over the obstacles (the rivers, ravines, etc.). Suspension clamps meet TU 3449-208-76935199-2007 requirements.

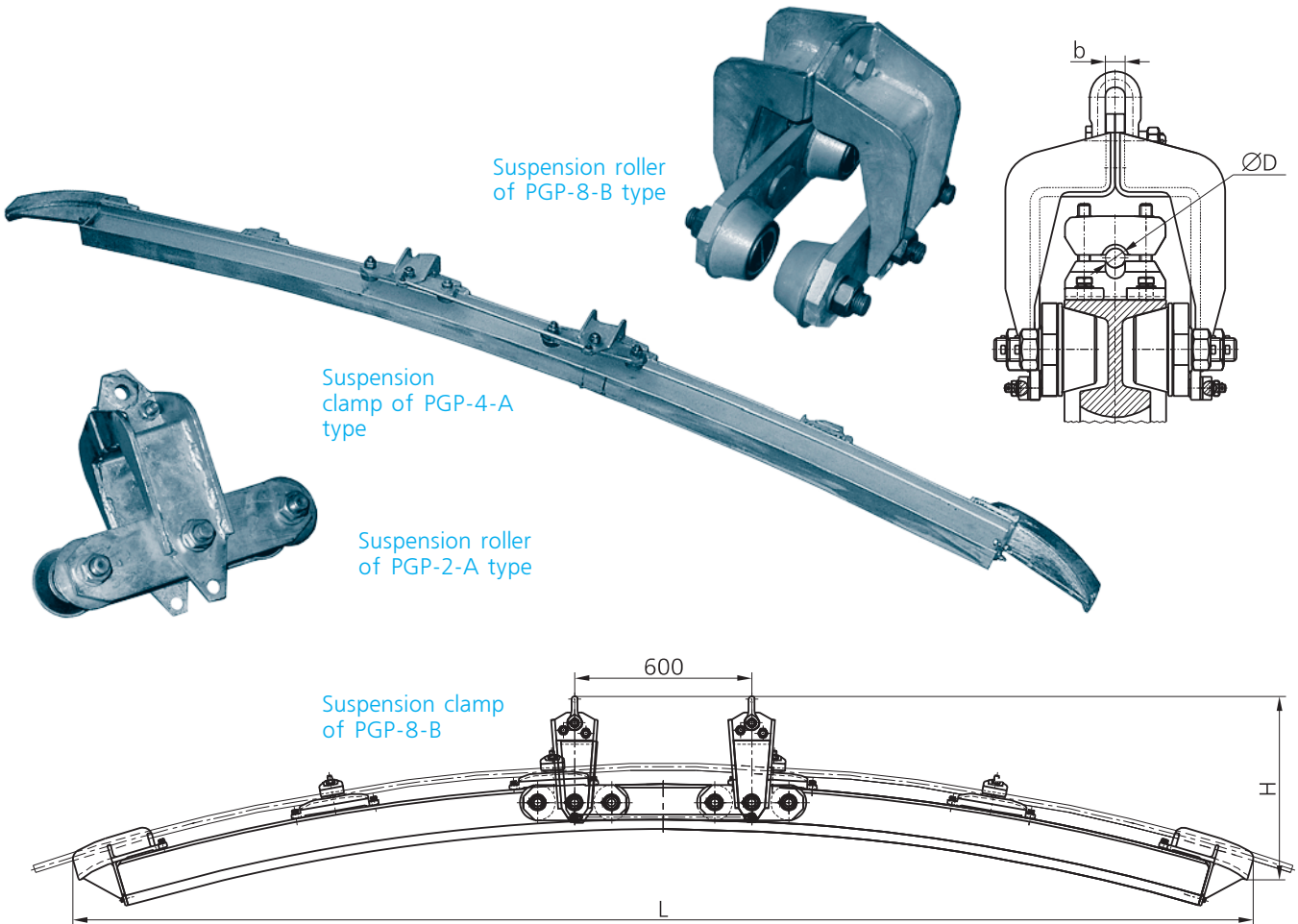

suspension fittings

Reference designation*	D, mm	For steel-aluminum conductors with GOST 839-80		For steel ropes with GOST 3064-80		Dimensions, mm			Weight, kg
		Section, mm ²	Diameter, mm	Section, mm ²	Diameter, mm	L	H	b	
PGP-8-B	25	300/39, 300/48, 300/66, 300/67	24; 24.1; 24.5	—	—	4000	710	29	335
	28	400/18, 400/22, 400/51, 400/64	26; 26.6; 27.5; 27.7	—	—				
	31	400/93, 300/204, 500/64	29.1; 29.2; 30.6	—	—				
	35	500/204, 600/72	34.5; 33.2	—	—				
	38	500/336	37.5	—	—				
	49	Sleeve MZ-30-1	48	—	—				
	60	Sleeve MZ-40-1	59	—	—				
	19	—	—	168.17; 197.29	17.0; 18.5				380
23	—	—	298.52	22.5					
PGP-4-A	25	300/39, 300/48, 300/66, 300/67	24; 24.1; 24.5; 24.5	—	—	3410	550	23	88
	30	400/18, 400/22, 400/51, 400/64, 400/93, 300/204	26; 26.6; 27.5; 27.8; 29.1; 29.2	—	—				
	19	—	—	168.17; 197.29	17.0; 18.5				100
	23	—	—	262.51; 298.52	21; 22.5				
	13.5	Earthwire OKGTS-1-24-(G652)-13.3/118			13.3				
26	Earthwire OKGT(DE14.6) with protective cover PZS-15.7/16.0-02			25.24	100				
PGP-4-B	25	300/39, 300/48, 300/66, 300/67	24; 24.1; 24.5; 24.5	—	—	2500	480	23	80
	30	400/18, 400/22, 400/51, 400/64, 400/93, 300/204	26; 26.6; 27.5; 27.7; 29.1; 29.2	—	—				
	19	—	—	168.17; 197.29	17.0; 18.5				89
	23	—	—	262.51; 298.52	21; 22.5				
PGP-2-A	25	300/39, 300/48, 300/66, 300/67	24; 24.1; 24.5; 24.5	—	—	3410	565	19	73
	30	400/18, 400/22, 400/51, 400/64, 400/93, 300/204	26; 26.6; 27.5; 27.8; 29.1; 29.2	—	—				
	19	—	—	168.17; 197.29	17.0; 18.5				85
	23	—	—	262.51; 298.52	21; 22.5				
PGP-2-B	25	300/39, 300/48, 300/66, 300/67	24; 24.1; 24.5; 24.5	—	—	2520	460	19	63
	30	400/18, 400/22, 400/51, 400/64, 400/93, 300/204	26; 26.6; 27.5; 27.7; 29.1; 29.2	—	—				
	19	—	—	168.17; 197.29	17.0; 18.5				74
	23	—	—	262.51; 298.52	21; 22.5				
	26	Fiber optic cable DSt-50-6z-6/48 with protective cover PZS-18.3/18.7-01 (3000)			25.9				

* please specify the diameter and type of the conductor or wire when ordering clamps

Special spacer of RS-6-400 type

Special spacer of RS-6-400 type is intended for fastening a tube of shield attachment and phase conductors of tension insulating strings in power lines. Spacer ensures spacing of 400 mm between two phase conductors. Minimum failing load – 2 kN. Weight – 3.84 kg. Spacer meet TU 3449-129-00111120-98 requirements.

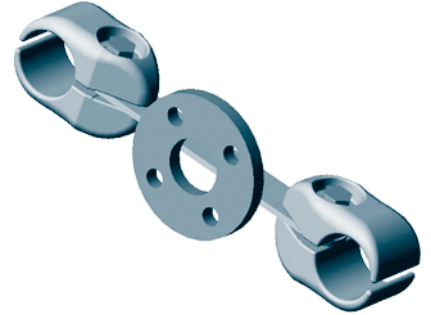
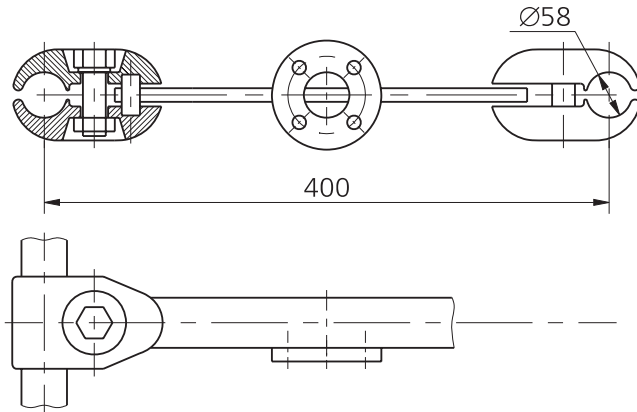

Special spacers of 3RS type

Special spacers of 3RS type are intended for supporting loops of insulating strings in power lines. Spacers meet TU 3449-129-00111120-98 requirements.

Reference designation	Conductor diameter, mm	Minimum failing load, kN	Weight, kg
3RS-2-400	21.6...26.6	1.96	112.6
3RS-3-400	27.5...30.6	1.96	112.6
3RS-4-400	31.5...37.7	1.96	112.5

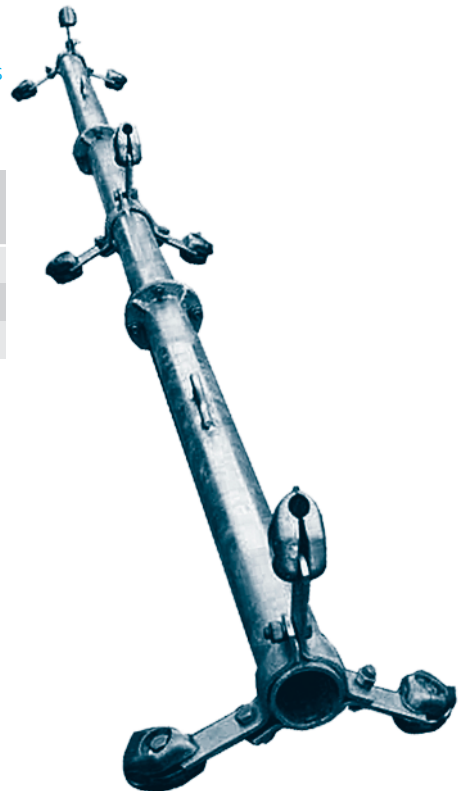
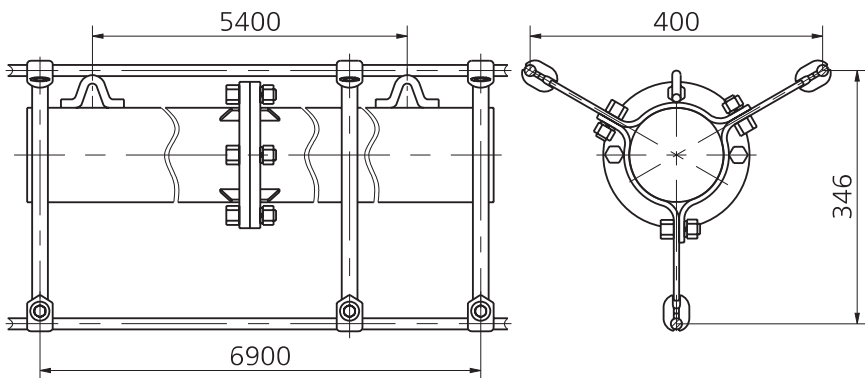

Special spacers of 3RS type

Special spacers of 3RS type are intended for supporting loops of insulating strings in power lines.

Spacers ensure fixed spacings between three phase conductors.

Spacers meet TU 3449-129-0011120-98 requirements.

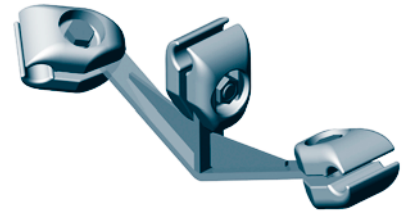

Reference designation	Dimensions, mm	Conductor diameter, mm	Minimum failing load, kN	Weight, kg
	C			
3RS-2-3	400	21.6...26.6	1.96	2.9
3RS-2-3a	400	21.6...26.6	1.96	3.54
3RS-3-3	400	27.5...30.6	1.96	2.83
3RS-3-3a	400	27.5...30.6	1.96	3.54

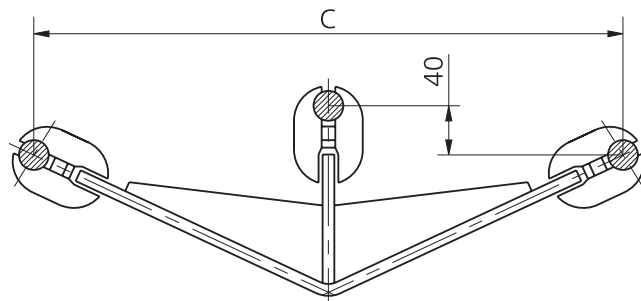

Special spacers of 4RS type

Special spacers of 4RS type are intended for supporting loops of insulating strings in power lines.

Spacers ensure fixed spacings between four phase conductors.

Spacers meet TU 3449-129-0011120-98 requirements.

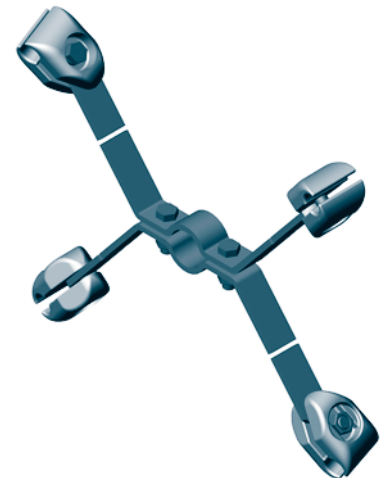

Reference designation	Dimensions, mm	Conductor diameter, mm	Minimum failing load, kN	Weight, kg
	C			
4RS-3-400	400	27.5...30.6	2	4.73
4RS-2-925	925	22.4...24.0	2.45	8
4RS-2-925A	925	21.6...26.6	2.45	8
4RS-3-925	925	27.5...30.6	2.45	7.6
4RS-3-925A	925	27.5...30.6	2.45	8.55
4RS-400-1	400	59/51.5	2	7.44

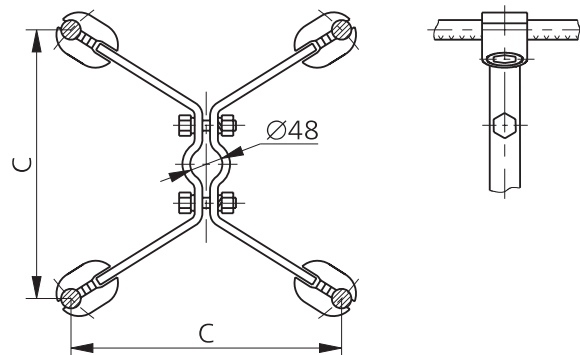

Special spacers of SRS type

Special spacers of SRS type are intended for supporting loops of tension insulating strings of power lines.

Spacers ensure fixed spacings between five phase conductors.

Spacers meet TU 3449-129-0011120-98 requirements.

Reference designation	Dimensions, mm		Conductor diameter, mm	Minimum failing load, kN	Weight, kg
	C	D			
5RS-3-400	400	680	27.5...30.6	—	7.6
5RS-5-1	600	1020	46.5	2	7.87
5RS-5-1A	600	1020	46.5	2	10.17
5RS-2-400M	400	765	20.5...21.6	—	7.96
5RS-2-450A	450	765	22.4...24.0	—	8.38
5RS-2-450M	450	765	20.5...21.6	—	8.39

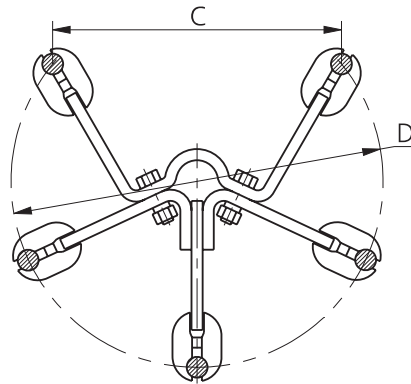

Special spacer of 6RS type intended for PA-500 conductors

Special spacer of 6RS type is intended for supporting loops of tension insulating strings in power lines.

Spacer ensures fixed spacings between six phase conductors.

Minimum failing load – 1.96 kN.

Weight – 18.0 kg.

Spacer meet TU 3449-129-0011120-98 requirements.

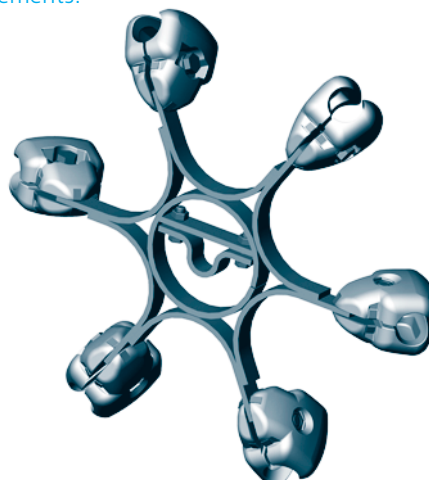
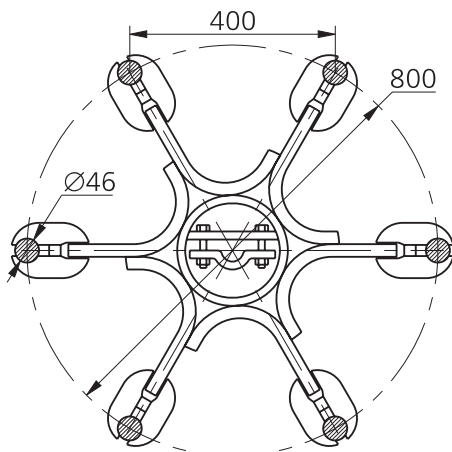

Special spacer of 8RS-3-400A type

Special spacer of 8RS-3-400A type is intended for supporting loops of tension insulating strings in power lines. Spacer ensures fixed spacings between eight phase conductors. Minimum failing load – 30 kN. Weight – 340.0 kg. Spacer meet TU 3449-129-0011120-98 requirements.

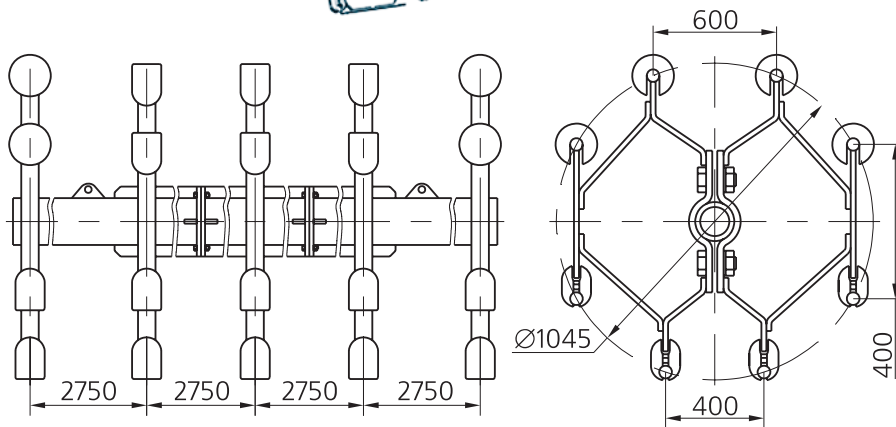
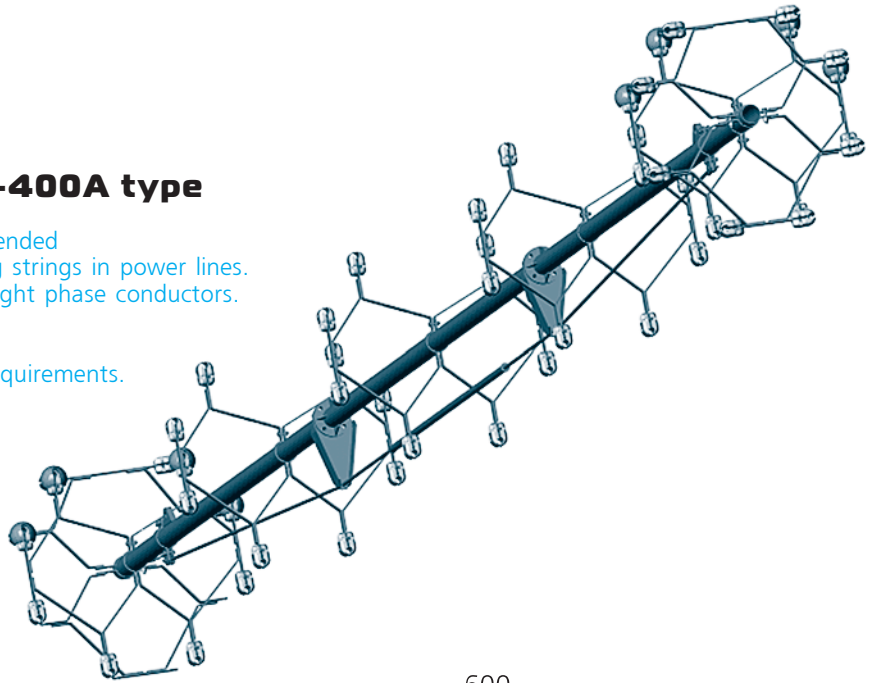

Spacers of RG type

Spacers of RG type ensure fixed spacings between two phase conductors in overhead power lines.
Spacers meet TU 3449-129-0011120-98 requirements.

Reference designation	Dimensions, mm			Conductor diameter, mm	Minimum failing load, kN	Weight, kg	
	L	B	b				
RG-1-300	300	25	4	15.2...18.9	1.96	0.624	
RG-1-400	400	40	6			1.1	
RG-1-500	500	40	6			1.3	
RG-2-300	300	30	8	21.6...26.6	1.96	1.6	
RG-2-400	400					1.8	
RG-2-485	485					2	
RG-2-500	500					2	
RG-2-600	600					2.2	
RG-2-650	650			2.3			
RG-3-400	400			27.5...30.6		1.96	1.8
RG-3-500	500						2
RG-3-600	600						2.2
RG-3-650	650			31.5...37.7		1.96	2.3
RG-4-400	400	1.8					
RG-4-500	500	2					
RG-4-600	600	2.2					
RG-4-650	650	Ø33.5	-	1.96	2.3		
RG-5-400	400				2.2		
RG-5-600	600				2.54		
RG-2-850	850				23.1	3.45	
RG-3-850	850				29.4	3.45	
RG-4-850	850	33.2	3.43				
RG-4-970	970	30	8	51.6...59.0	1.96	3.4	
RG-6-400	400					8	2.4

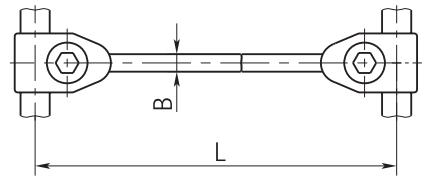
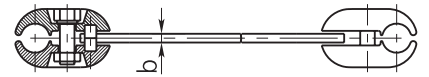
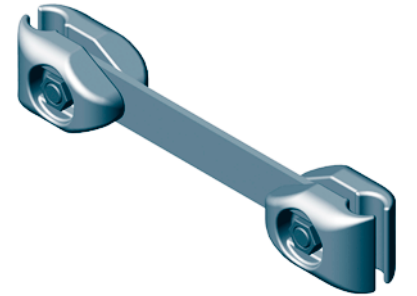

Bundle configuration spacers of 3RG type

Dead end spacers of 3RG type are intended for ensuring fixed spacings between three phase conductors in overhead power lines and opendoor switchgears.
Spacers are equipped with bolts for tightening two-part clamps.
Spacers meet TU 3449-129-0011120-98 requirements.

Reference designation	Dimensions, mm		Conductor diameter, mm	Minimum failing load, kN	Weight, kg
	L	2R			
3RG-3-400	400	30	27.5...30.6	1.96	3.985
3RG-3-400A	400	30	27.5...30.6	1.96	4.1
3RG-5-1	400	46	45/37	2	4.1
3RG-5-1A	400	46	45/37	2	4.55

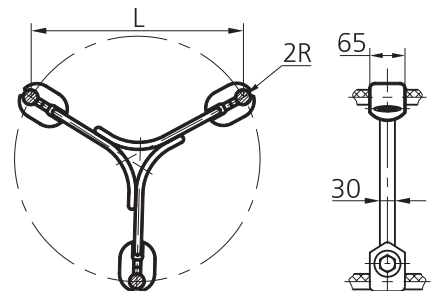

Spacers of RGU type

Reference designation	Dimensions, mm			Conductor diameter, mm	Minimum failing load, kN	Weight, kg
	L	B	b			
RGU-0-300	300	25	8	13.0...16.8	1.96	1.3
RGU-0-400	400					1.5
RGU-0-500	500					1.6
RGU-1-300	300			17.1...19.8		1.4
RGU-1-400	400					1.6
RGU-1-500	500					1.68
RGU-2-300	300	40	21.6...26.6	2.16		
RGU-2-400	400			2.35		
RGU-2-485	485			2.51		
RGU-2-500	500			2.54		
RGU-2-600	600			2.73		
RGU-2-650	650			2.82		
RGU-3-400	400	40	27.5...30.6	2.31		
RGU-3-500	500			2.5		
RGU-3-600	600			2.69		
RGU-3-650	650			2.78		
RGU-4-400	400			31.5...37.7	2.27	
RGU-4-500	500				2.46	
RGU-4-600	600	2.61				
RGU-4-650	650	2.74				
RGU-5-400	400	30	8	42.5...46.5	2.57	
RGU-5-600	600	2.95				
RGU-3-450	450	40	6	27.5...30.6	2.35	
RGU-4-450	450			31.5...37.5	2.57	

Spacers of RGU type ensure fixed spacings between two phase conductors in overhead power lines. Spacers meet TU 3449-129-0011120-98 requirements.

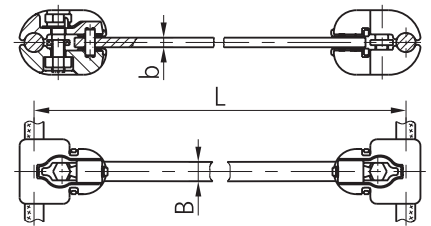
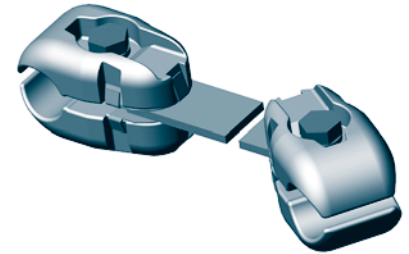

Bundle configuration spacers of 4RG type

Dead end spacers of 4RG type are intended for ensuring fixed spacings between four phase conductors in overhead power lines and opendoor switchgears. Spacers are equipped with bolts for tightening two-part clamps. Spacers meet TU 3449-129-0011120-98 requirements.

Reference designation	Dimensions, mm		Conductor diameter, mm	Minimum failing load, kN	Weight, kg
	L	2R			
4RG-6-400	400	58	59	1	6.6
4RG-3-400	400	30	27.5...30.6	2	4.97
4RG-3-400A					6.04
4RG-3-600					7.41
4RG-3-600A	600	30	27.5...30.6		8.24
4RG-4-400	400	36	31.5...37.7		4.93
4RG-4-400A					6.04
4RG-4-600				600	36
4RG-4-600A	600	36	31.5...37.7	8.24	

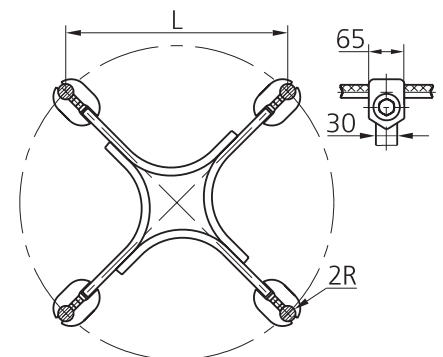

Bundle configuration spacers of 5RG type

Dead end spacers of 5RG type are intended for ensuring fixed spacings between five phase conductors in overhead power lines and opendoor switchgears. Spacers are equipped with bolts for tightening two-part clamps. Spacers meet TU 3449-129-0011120-98 requirements.

Reference designation	Dimensions, mm		Conductor diameter, mm	Minimum failing load, kN	Weight, kg
	C	D			
5RG-2-300	300	510	21.6...26.6	2	5.9
5RG-2-300A					7.2
5RG-2-400	400	680	21.6...26.6		7.1
5RG-2-400A					8.4
5RG-3-400	400	680	27.5...30.6		7.1
5RG-3-400A					8.3

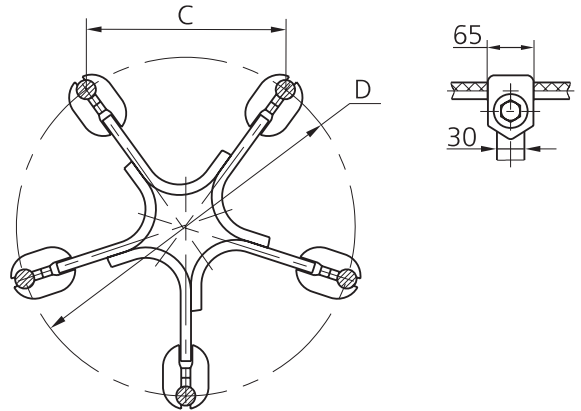

Spacers of 5RG type

Dead end spacers of 5RG type are intended for ensuring fixed spacings between five phase conductors in overhead power lines and opendoor switchgears. Spacers are equipped with bolts for tightening two-part clamps. Spacers meet TU 3449-129-0011120-98 requirements.

Reference designation	Dimensions, mm			Conductor diameter, mm	Minimum failing load, kN	Weight, kg
	D	C	2R			
5RG-4-600	1020	600	36	37.5	2	14.81
5RG-5-600A	1020	600	46	46.5	2	15.7

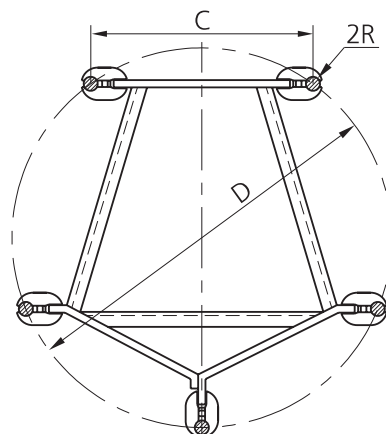
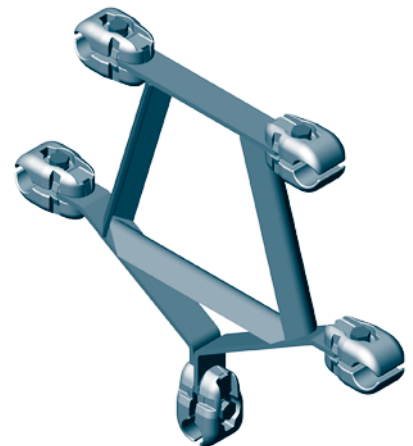

Spacer of 6RG-5-400 type intended for hollow conductors (PA-500) with the diameter of 37 mm...45 mm

Spacer of 6RG-5-400 type is intended for ensuring fixed spacings between six phase conductors in overhead power lines and opendoor switchgears.
 Minimum failing load – 1.96 kN.
 Weight – 17.0 kg.
 Spacer meet TU 3449-129-00111120-98 requirements.

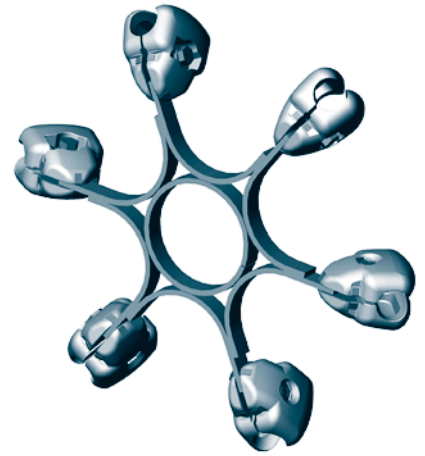
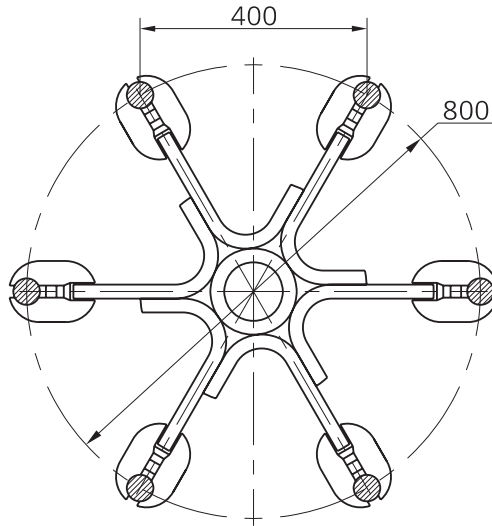

Spacers of 8RG type

Dead end spacers of 8RG type are intended for ensuring fixed spacings between eight phase conductors in overhead power lines and opendoor switchgears.
 Spacers are equipped with bolts for tightening two-part clamps.
 Spacers meet TU 3449-129-00111120-98 requirements.

Reference designation	Dimensions, mm			Conductor diameter, mm	Minimum failing load, kN	Weight, kg
	D	C	2R			
8RG-2-400B	1045	400	25	21.6...26.6	1.96	20.8
8RG-3-400B	1045	400	30	27.5...30.6	1.96	20.6

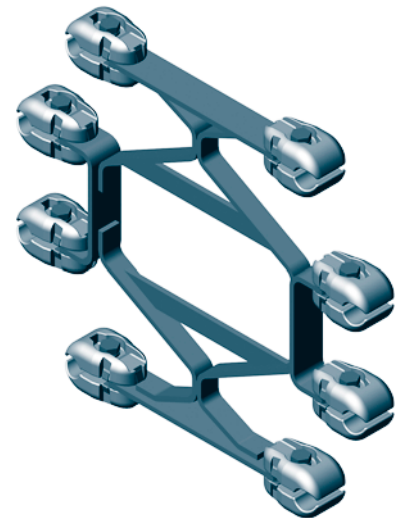
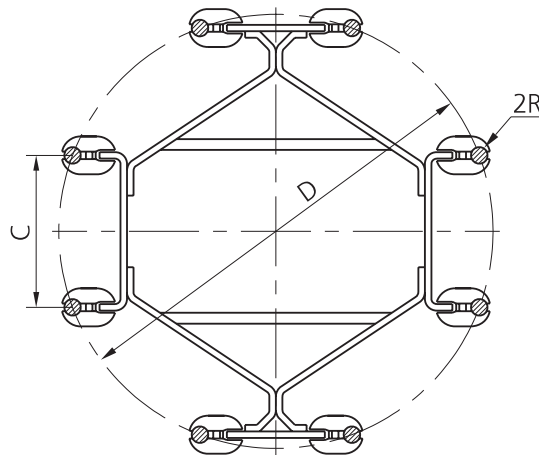

Loaded spacers of RU type

Loaded spacers of RU type are installed on loops to limit swinging of two conductors. Spacers meet TU 3449-129-0011120-98 requirements.

Reference designation	Dimensions, mm		Conductor diameter, mm	Minimum failing load, kN	Weight, kg
	L	2R			
RU-2-400	432	25	21.6...26.6	1.96	6.25
RU-3-400	438	30	27.5...30.6		6.25
RU-4-400	444	36	31.5...37.7		6.23

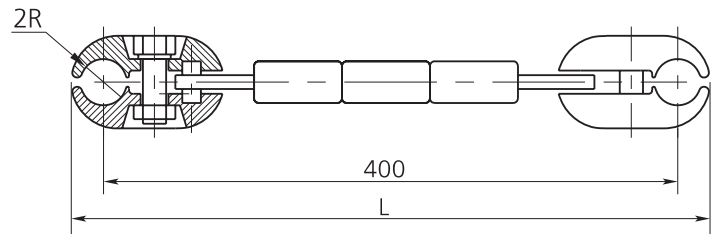
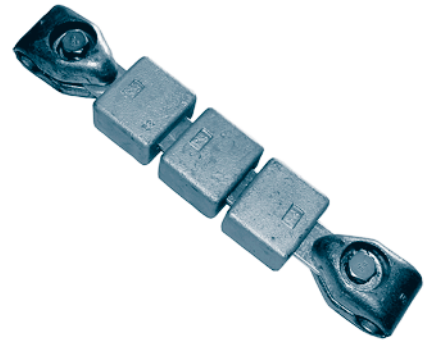

Insulating spacers of RGIF type

Dead end insulating spacers of RGIF type are intended for ensuring fixed spacings between insulated phase conductors and earthwires in power lines.

Spacers are equipped with a protective coating on insulating component to prevent environmental influence.

Spacers meet TU 3449-142-0011120-98 requirements.

Reference designation	Dimensions, mm					Conductor diameter, mm	Minimum failing load, kN	Weight, kg
	L	B	S	2R	D			
RGIF-0-400G	400	44	62	16	14	13.0...16.8	2.5	1.3
RGIF-1-400G	400	44	62	20	14	17.1...19.8		1.4
RGIF-0-600G	600	44	62	16	14	13.0...16.8		1.4
RGIF-1-600G	600	44	62	20	14	17.1...19.8		1.5
RGIF-2-400	400	65	72	25	15.8	21.6...26.6		2.36
RGIF-2-500	500	65	72	25	15.8	21.6...26.6		2.41
RGIF-2-600	600	65	72	25	15.8	21.6...26.6		2.47
RGIF-2-800	800	65	72	25	15.8	21.6...26.6		2.58
RGIF-2-850	850	65	72	25	15.8	21.6...26.6		2.61
RGIF-3-400	400	65	72	30	15.8	27.5...30.6		2.36
RGIF-3-500	500	65	72	30	15.8	27.5...30.6		2.41
RGIF-3-600	600	65	72	30	15.8	27.5...30.6		2.47
RGIF-5-800	800	65	81	46	15.8	46.5	2.65	

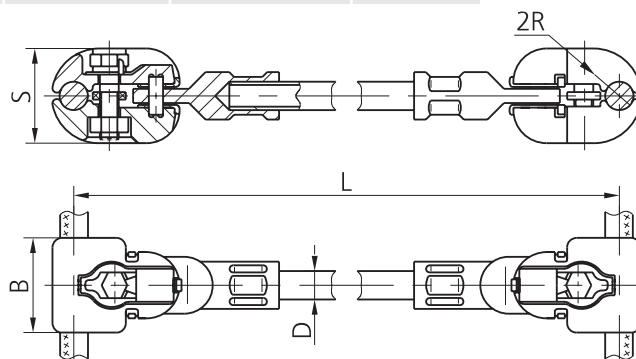
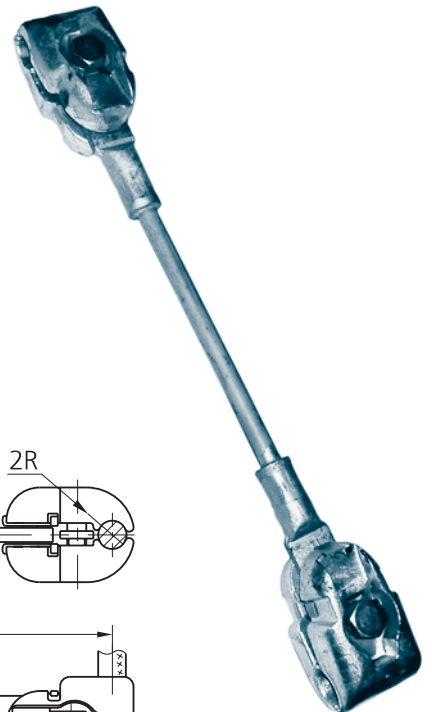

Spacer-dampers of RD and 3RD type

Spacer-dampers of RD, 3RD type are intended to ensure fixed distance of two and three phase conductors in overhead power lines and also for extinction of sub-fluctuations (fluctuation in sub-spans between the spacers).
 Spacer-dampers meet TU 3449-235-76935199-2010 requirements.

Reference designation	Range diameters of the conductors $D_{cond.}$, mm AC, ACKP, ACKC, ACK according to GOST 839-80, ACk2u according to TU 16.K03-53-2012	Dimensions, mm				Mechanical load, kH		Weight, kg
		R	L	L1	H	compression	stretching	
RD-2-400A	21.6–26.6	12.5	445	400	150	10	5	3.4
RD-3-400A	27.5–30.6	15.0	445	400	150			3.3
RD-4-400A	31.5–37.7	18.0	452	400	153			3.5
RD-2-500A	21.6–26.6	12.5	545	500	150			3.8
RD-3-500A	27.5–30.6	15.0	545	500	150			3.7
RD-4-500A	31.5–37.7	18.0	552	500	153			3.9
RD-2-600A	21.6–26.6	12.5	645	600	150			4.1
RD-3-600A	27.5–30.6	15.0	645	600	150			4.0
RD-4-600A	31.5–37.7	18.0	652	600	153			4.2
3RD-2-400A	21.6–26.6	12.5	445	400	396			4.8
3RD-3-400A	27.5–30.6	15.0	445	400	396			5.8
3RD-4-400A	31.5–37.7	18.0	452	400	405			6.0
3RD-2-500A	21.6–26.6	12.5	545	500	485			6.8
3RD-3-500A	27.5–30.6	15.0	545	500	485			6.8
3RD-4-500A	31.5–37.7	18.0	554	500	485			7.0
3RD-2-600A	21.6–26.6	12.5	645	600	494			7.8
3RD-3-600A	27.5–30.6	15.0	645	600	568			7.8
3RD-4-600A	31.5–37.7	18.0	654	600	577			8.0

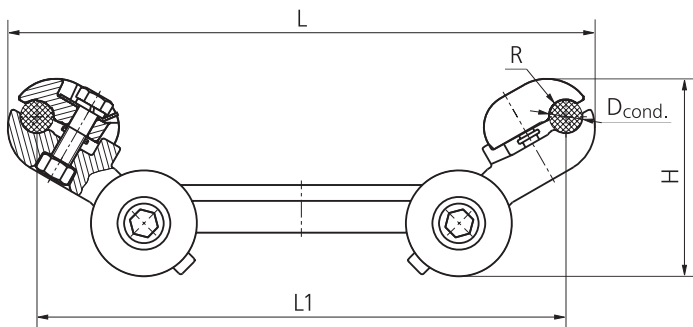

Spacer-dampers of RD and 3RD type

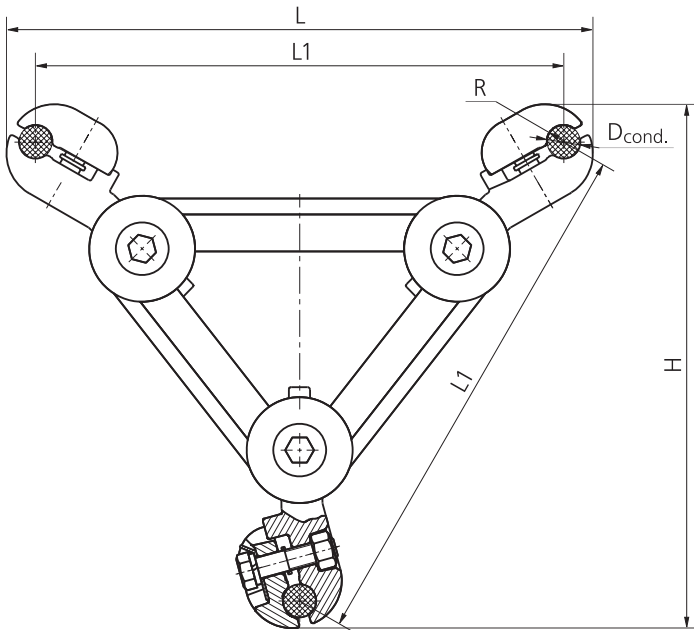

Advantages of spacer-dampers of RD, 3RD type

It has flexible damper joints which are able to move in two planes with the conductor, and making units which take up vibratory energy. Thanks to it the oscillation angles and the level of conductor's bend on the binding side are reduced and as a result the failure probability of spacer and conductor is decreased.

Dead end spacers of R type intended for 21.6 mm...35.6 mm diameter conductors

Dead end spacers of R type are applied in substations. Spacers meet TU 3449-129-0011120-98 requirements.

Reference designation	Conductor diameter, mm	Dimensions, mm				Weight, kg
		2R	H	L	I	
R-2-120-A	21.6...25.2	25	50	154	64	0.64
R-3-120-A	25.6...30.2	30	60	160	60	0.85
R-4-120-A	30.3...35.6	36	70	170	50	0.75

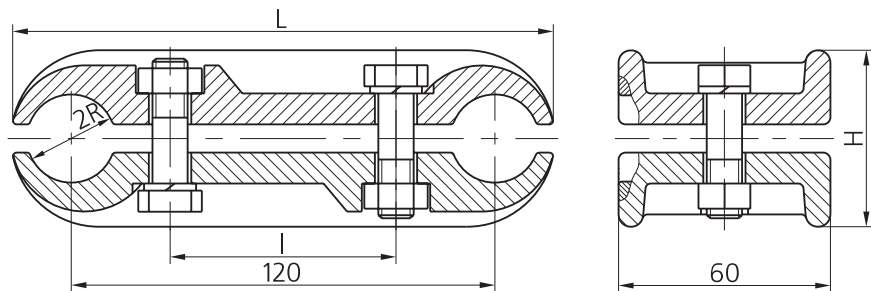

Intraphase spacers-dampers of distant type for bundle conductors of overhead transmission lines up to 750 kV

Spacers-dampers are intended to preserve the distance between the wires of the bundle conductors of transmission lines within the reasonable limits, preventing collision of wires of bundle conductors, damping aeolian vibration, damping swinging. Spacers-dampers can be used as in the construction of new as well as maintenance of the existing overhead lines.

Intraphase spacers-dampers of distant type are manufactured in climatic category of boreal climate, environmental class 1 according to GOST standard 15150-69.

Reference designation	Distance between conductors, L, mm	Range diameters of the conductor, mm	Conductors of AC, ACKP, ACKC, ACK according to GOST 839-80 Section, mm ²	Conductors according to TU 3510-001-699 48 333-2012		Weight, kg
				AAAC-Z	AACSRZ	
2RGD-014-01	400	18.8–19.8	185/29–205/27	AAAC-Z242-ZZ; AAAC-Z261-ZZ	AACSRZ 251	3.02
2RGD-015-01	500					4.00
2RGD-016-01	600					4.14
3RGD-014-01	400					4.31
3RGD-015-01	500					5.50
3RGD-016-01	600					5.91
5RGD-014-01	400					7.00
5RGD-015-01	500					8.50
5RGD-016-01	600					10.00
2RGD-024-01	400	21.0–23.2	240/32–185/128	AAAC-Z301-ZZ; AAAC-Z346-ZZ; AAAC-Z366-ZZ	AACSRZ 339	3.02
2RGD-025-01	500					4.00
2RGD-026-01	600					4.14
3RGD-024-01	400					4.31
3RGD-025-01	500					5.50
3RGD-026-01	600					5.91
5RGD-024-01	400					7.00
5RGD-025-01	500					8.50
5RGD-026-01	600					10.00
2RGD-034-01	400	24.0–25.2	300/39–330/43	not applicable	not applicable	3.02
2RGD-035-01	500					4.00
2RGD-036-01	600					4.14
3RGD-034-01	400					4.31
3RGD-035-01	500					5.50
3RGD-036-01	600					5.91
5RGD-034-01	400					7.00
5RGD-035-01	500					8.50
5RGD-026-01	600					10.00

Intraphase spacers-dampers of distant type for bundle conductors of overhead transmission lines up to 750 kV

Reference designation	Distance between conductors, L, mm	Range diameters of the conductor, mm	Conductors of AC, ACKP, ACKC, ACK according to GOST 839-80 Section, mm ²	Conductors according to TU 3510-001-699 48 333-2012		Weight, kg
				AAAC-Z	AACSRZ	
2RGD-044-01	400	26.0–27.7	400/18–400/64	AAAC-Z455-ZZ; AAAC-Z504-ZZ	AACSRZ 527	3.02
2RGD-045-01	500					4.00
2RGD-046-01	600					4.14
3RGD-044-01	400					4.31
3RGD-045-01	500					5.50
3RGD-046-01	600					5.91
5RGD-044-01	400					7.00
5RGD-045-01	500					8.50
5RGD-046-01	600					10.00
2RGD-054-01	400	28.8–30.1	450/56–500/64	AAAC-Z538-ZZ	not applicable	3.02
2RGD-055-01	500					4.00
2RGD-056-01	600					4.14
3RGD-054-01	400					4.31
3RGD-055-01	500					5.50
3RGD-056-01	600					5.91
5RGD-054-01	400					7.00
5RGD-055-01	500					8.50
5RGD-056-01	600					10.00
2RGD-064-01	400	30.6–32.4	500/64–550/71	AAAC-Z635-1Z; AAAC-Z648-ZZ; AAAC-Z666-ZZ; AAAC-Z707-ZZ	AACSRZ 647; AACSRZ 649	3.02
2RGD-065-01	500					4.00
2RGD-066-01	600					4.14
3RGD-064-01	400					4.31
3RGD-065-01	500					5.50
3RGD-066-01	600					5.91
5RGD-064-01	400					7.00
5RGD-065-01	500					8.50
5RGD-066-01	600					10.00

Intraphase spacers-dampers of distant type for bundle conductors of overhead transmission lines up to 750 kV

Reference designation	Distance between conductors, L, mm	Range diameters of the conductor, mm	Conductors of AC, ACKP, ACKC, ACK according to GOST 839-80 Section, mm ²	Conductors according to TU 3510-001-699 48 333-2012		Weight, kg
				AAAC-Z	AACSRZ	
2RGD-074-01	400	32.7–35.1	600/72–650/79	not applicable	AACSRZ 747; AACSRZ 797; AACSRZ 835	3.02
2RGD-075-01	500					4.00
2RGD-076-01	600					4.14
3RGD-074-01	400					4.31
3RGD-075-01	500					5.50
3RGD-076-01	600					5.91
5RGD-074-01	400					7.00
5RGD-075-01	500					8.50
5RGD-076-01	600					10.00
2RGD-084-01	400	36.2–37.7	700/86–750/93	AAAC-Z928-3Z	not applicable	3.02
2RGD-085-01	500					4.00
2RGD-086-01	600					4.14
3RGD-084-01	400					4.31
3RGD-085-01	500					5.50
3RGD-086-01	600					5.91
5RGD-084-01	400					7.00
5RGD-085-01	500					8.50
5RGD-086-01	600					10.00

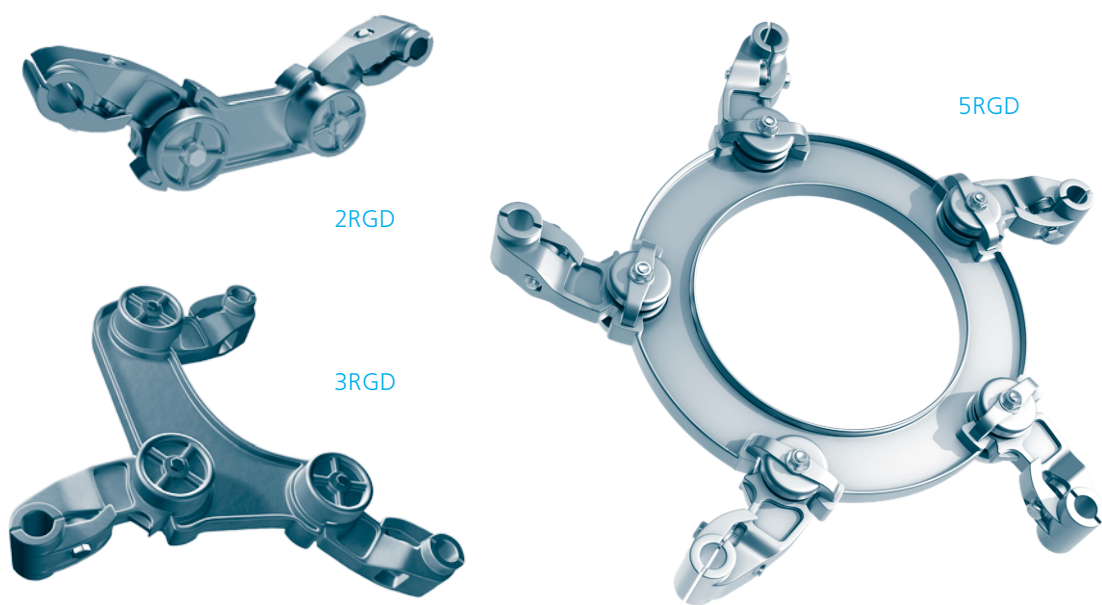

Vibration dampers of GPG type

Vibration dampers of GPG type are used for damping vibration of conductors installed on long-span crossings in power lines. In total there are manufactured more than 70 kinds of vibration dampers of GPG type. Dampers meet TU 3449-132-0011120-98 requirements.

Reference designation	Dimensions, mm					Weight, kg
	A	H	L	d	D	
GPG-0.8-9.1-300/10	68	102	300	9.1	9.0...11.0	2.43
GPG-0.8-9.1-300/13	69	104.5	300	9.1	11.0...14.0	2.43
GPG-0.8-9.1-300/16	72	108	300	9.1	14.0...17.0	2.45
GPG-0.8-9.1-350/13	69	103	350	9.1	11.0...14.0	2.45
GPG-0.8-9.1-350/16	72	108	350	9.1	14.0...17.0	2.47
GPG-0.8-9.1-400/10	68	102	400	9.1	9.0...11.0	2.47
GPG-0.8-9.1-400/13	69	104.5	400	9.1	11.0...14.0	2.47
GPG-0.8-9.1-400/23	78	119	400	9.1	20.0...26.0	2.69
GPG-0.8-9.1-450/16	72	108	450	9.1	14.0...17.0	2.51
GPG-1.6-11-350/10	83	123	350	11	9.0...11.0	4.37
GPG-1.6-11-350/13	84	125.5	350	11	11.0...14.0	4.37
GPG-1.6-11-400/13	84	125.5	400	11	11.0...14.0	4.4
GPG-1.6-11-400/16	87	129	400	11	14.0...17.0	4.42
GPG-1.6-11-400/20	90	135	400	11	17.0...20.0	4.46
GPG-1.6-11-450/13	84	125.5	450	11	11.0...14.0	4.43
GPG-1.6-11-450/16	87	129	450	11	14.0...17.0	4.45
GPG-1.6-11-450/20	90	135	450	11	9.0...11.0	4.49
GPG-1.6-11-450/23	93	140	450	11	20.0...26.0	4.65
GPG-1.6-11-450/31	97	146	450	11	26.0...32.0	4.75
GPG-1.6-11-450/35	98	149	450	11	32.0...35.0	4.75
GPG-1.6-11-500/13	84	125.5	500	11	11.0...14.0	4.46
GPG-1.6-11-500/16	87	129	500	11	14.0...17.0	4.48
GPG-1.6-11-500/20	90	135	500	11	17.0...20.0	4.52
GPG-1.6-11-500/23	93	140	500	11	9.0...11.0	4.68
GPG-1.6-11-550/16	87	129	550	11	14.0...17.0	4.52
GPG-1.6-11-550/20	90	135	550	11	17.0...20.0	4.56
GPG-1.6-11-550/23	93	140	550	11	9.0...11.0	4.74
GPG-1.6-13-350/10	83	123	350	13	11.0...14.0	4.54
GPG-1.6-13-350/13	84	124	350	13	11.0...14.0	4.54
GPG-1.6-13-350/20	90	135	350	13	11.0...14.0	4.60
GPG-1.6-13-400/16	87	129	400	13	14.0...17.0	4.6
GPG-1.6-13-400/20	90	135	400	13	17.0...20.0	4.64
GPG-1.6-13-400/23	93	140	400	13	20.0...26.0	4.8
GPG-1.6-13-450/20	90	135	450	13	17.0...20.0	4.69
GPG-1.6-13-450/23	93	140	450	13	20.0...26.0	4.85

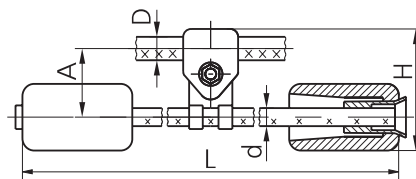

Vibration dampers of GPG type

Reference designation	Dimensions, mm					Weight, kg
	A	H	L	d	D	
GPG-2.4-11-400/13	84	129	400	11	11.0...14.0	6.01
GPG-2.4-11-400/23	93	143.5	400	11	9.0...11.0	6.23
GPG-2.4-11-450/13	84	129	450	11	11.0...14.0	6.11
GPG-2.4-11-450/16	87	132.5	450	11	14.0...17.0	6.13
GPG-2.4-11-500/13	84	129	500	11	11.0...14.0	6.14
GPG-2.4-11-500/16	87	132.5	500	11	14.0...17.0	6.16
GPG-2.4-11-500/20	90	138.5	500	11	17.0...20.0	6.2
GPG-2.4-11-500/23	93	143.5	500	11	9.0...11.0	6.38
GPG-2.4-11-550/20	90	138.5	550	11	17.0...20.0	6.23
GPG-2.4-11-550/23	93	143.5	550	11	20.0...26.0	6.4
GPG-2.4-11-600/23	93	143.5	600	11	20.0...26.0	6.43
GPG-2.4-13-400/16	87	132.5	400	13	11.0...14.0	6.28
GPG-2.4-13-400/20	90	138.5	400	13	17.0...20.0	6.32
GPG-2.4-13-400/31	97	149.5	400	13	11.0...14.0	6.52
GPG-2.4-13-450/13	84	127.5	450	13	11.0...14.0	6.31
GPG-2.4-13-450/16	87	132.5	450	13	14.0...17.0	6.33
GPG-2.4-13-450/20	90	138.5	450	13	17.0...20.0	6.37
GPG-2.4-13-450/23	93	143.5	450	13	20.0...26.0	6.53
GPG-2.4-13-450/31	97	149.5	450	13	26.0...32.0	6.57
GPG-2.4-13-500/13	84	127.5	500	13	11.0...14.0	6.35
GPG-2.4-13-500/16	87	132.5	500	13	14.0...17.0	6.37
GPG-2.4-13-500/20	90	138.5	500	13	17.0...20.0	6.41
GPG-2.4-13-500/23	93	143.5	500	13	20.0...26.0	6.57
GPG-2.4-13-500/31	97	149.5	500	13	26.0...32.0	6.61
GPG-2.4-13-500/35	98	152.5	500	13	32.0...35.0	6.66
GPG-2.4-13-550/20	90	138.5	550	13	17.0...20.0	6.45
GPG-2.4-13-550/23	93	143.5	550	13	20.0...26.0	6.61
GPG-2.4-13-600/23	93	143.5	600	13	20.0...26.0	6.66

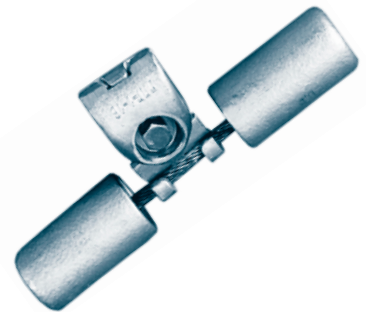

Vibration dampers of GPG type

Reference designation	Dimensions, mm					Weight, kg
	A	H	L	d	D	
GPG-3.2-11-550/31	97	154	550	11	26.0...32.0	7.8
GPG-3.2-13-450/16	87	136.5	450	13	14.0...17.0	8.01
GPG-3.2-13-450/20	90	142.5	450	13	17.0...20.0	8.05
GPG-3.2-13-450/23	93	147.5	450	13	20.0...26.0	8.21
GPG-3.2-13-450/31	97	153.5	450	13	26.0...32.0	8.25
GPG-3.2-13-450/38	100	159.5	450	13	35.0...38.0	8.27
GPG-3.2-13-500/20	90	142.5	500	13	17.0...20.0	8.09
GPG-3.2-13-500/35	98	156.5	500	13	32.0...35.0	8.34
GPG-3.2-13-550/20	90	142.5	550	13	17.0...20.0	8.13
GPG-3.2-13-550/23	93	147.5	550	13	20.0...26.0	8.29
GPG-3.2-13-550/31	97	153.5	550	13	26.0...32.0	8.33
GPG-3.2-13-600/23	93	147.5	600	13	20.0...26.0	8.34
GPG-3.2-13-600/31	97	153.5	600	13	26.0...32.0	8.38
GPG-3.2-13-600/35	98	156.5	600	13	32.0...35.0	8.43
GPG-3.2-13-650/35	98	156.5	650	13	32.0...35.0	8.47
GPG-3.2-13-650/38	100	159.5	650	13	35.0...38.0	8.49
GPG-4.0-13-500/20	90	145.5	500	13	17.0...20.0	9.77
GPG-4.0-13-500/23	93	150.5	500	13	20.0...26.0	9.93
GPG-4.0-13-500/38	100	162.5	500	13	35.0...38.0	9.99
GPG-4.0-13-550/20	90	145.5	550	13	17.0...20.0	9.81
GPG-4.0-13-550/23	93	150.5	550	13	20.0...26.0	9.97
GPG-4.0-13-550/31	97	156.5	550	13	26.0...32.0	10.01
GPG-4.0-13-600/31	97	156.5	600	13	26.0...32.0	10.06
GPG-4.0-13-600/35	98	159.5	600	13	32.0...35.0	10.11
GPG-4.0-13-600/38	100	162.5	600	13	35.0...38.0	10.08

Table of replacement of vibration dampers of GVN type to vibration dampers of GPG type

Reference designation	Range of used wires and cables, mm	Weight of cargo, kg	Weight of damper, kg	Brand of used vibration damper
GVN-2-9	8.9...9.8	0.8	2.3	GPG-0.8-9.1-300/10
GVN-2-13	10.7...13.5	0.8	2.3	GPG-0.8-9.1-350/13
GVN-3-12	11.0...12.6	1.6	4.0	GPG-1.6-11-400/13
GVN-3-13	13.0	1.6	4.3	GPG-1.6-11-450/13
GVN-3-17	14.0...17.5	1.6	4.1	GPG-1.6-11-450/16
GVN-4-14	14.0	2.4	5.6	GPG-2.4-11-450/13
GVN-4-22	17.6...22.4	2.4	5.7	GPG-2.4-11-500/20
GVN-5-25	22.1...25.6	3.2	7.7	GPG-3.2-13-550/23
GVN-5-30	30.6	3.2	7.8	GPG-3.2-13-550/31
GVN-5-34	32.0...33.1	3.2	7.8	GPG-3.2-13-600/35
GVN-5-38	35.6...37.7	3.2	7.9	GPG-3.2-13-650/38

Vibration dampers of GV-0.4/0.8/9.1-24 type for non-metal optical cables and earthwires D24 incorporating cables

Vibration dampers of GV-0.4/0.8/9.1-24 type with dead end fastening on a cable (earthwire) are intended for damping vibration of non-metal optical cables and earthwires incorporating cables, on long-span crossings of overhead power lines. Dampers meet GOST R 51177-98 requirements.

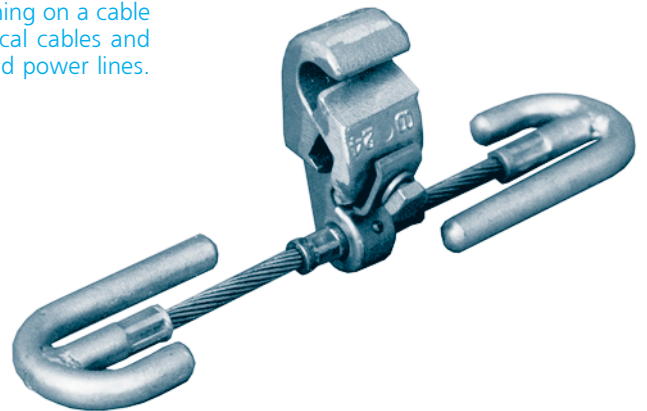
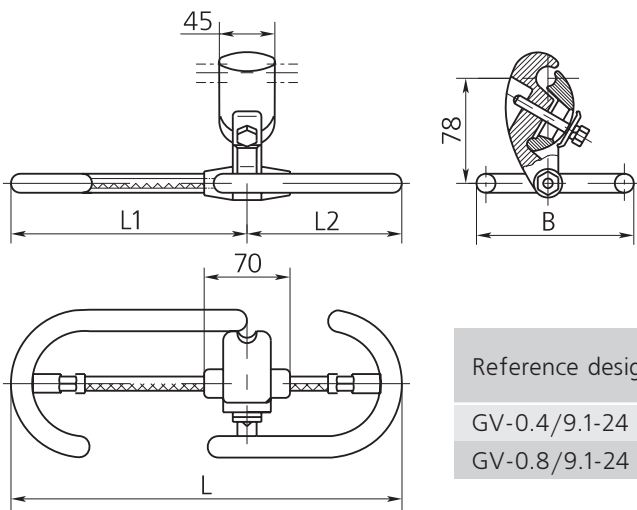

Reference designation	Dimensions, mm				Weight, kg
	L	L1	L2	B	
GV-0.4/9.1-24	340	185	155	80	1.37
GV-0.8/9.1-24	370	205	165	100	2.16

Vibration multiresonant dampers of GVM type

Vibration multiresonant dampers of GVM type are applied with the tight fastening on a conductor. Intended for vibration dampening of conductors and ground wires of overhead transmission lines.

Dampers meet TU 3449-258-76935199-2012 requirements.

Reference designation	Conductor diameter D, mm	Dimensions, mm			Weight, kg
		L	d	A	
GVM-A-0.8-9.1-300/10	9.0...11.0	306	9.1	68	2.4
GVM-A-0.8-9.1-350/10		356			2.5
GVM-A-1.6-11-350/13	11.0...14.0	348	11.0	84	4.2
GVM-A-1.6-11-350/16					4.2
GVM-A-1.6-11-400/16	14.0...17.0	388	11.0	87	4.3
GVM-A-1.6-11-450/16		438			4.4
GVM-A-1.6-11-450/20	17.0...20.0	438	11.0	90	4.5
GVM-A-2.4-11-450/16	14.0...17.0	434	11.0	87	5.9
GVM-A-2.4-11-450/23	20.0...26.0	484	11.0	93	6.1
GVM-A-2.4-11-500/20	17.0...20.0	534	11.0	90	6.1
GVM-A-2.4-11-550/23	20.0...26.0	508	13.0	93	6.3
GVM-A-3.2-13-500/23	26.0...32.0	558	13.0	97	8.0
GVM-A-3.2-13-500/31					8.1
GVM-A-3.2-13-550/31	32.0...35.0	608	13.0	98	8.2
GVM-A-3.2-13-600/31					8.3
GVM-A-3.2-13-600/35	32.0...35.0	608	13.0	98	8.4

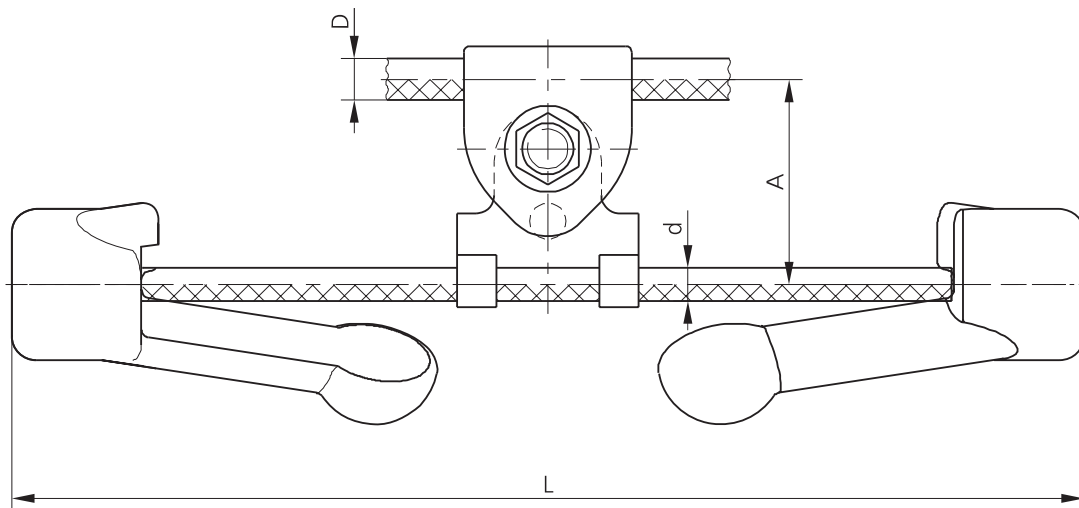

Vibration dampers of excentric weights of GP type and pendulums of MP type

Vibration dampers of excentric weights of GP type and pendulums of MP type are intended to restrict the amplitudes of vibration of conductors and earthwires of power transmission lines with number of half waves from 1 to 4 and to protect from sticking of ice to the conductors and wires of power transmission lines. The complete set with the protector is applied in the areas with intensive vibration of the conductors. For the areas with moderate vibration of the conductors it is possible to install the devices without application of the safety protector. The strength of sealing of the tap clamp on the conductor is 2.0 kN. Vibration dampers and pendulums meet TU 3449-206-76935199-2007 requirements.

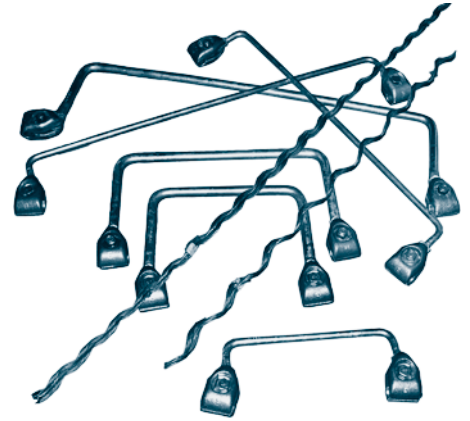

Reference designation	Dimensions, mm			Weight, kg	Completed with the clamp
	H	L	d		
GP-120	150	350	16	2.1	RG-2-400A-1
GP-150		950		3.15	RG-2-400A-1
GP-240-A		800	20	2.8	RG-3-300/650-1
GP-240-B		470		2.9	RG-3-300/650-1
GP-240-V		300		3.0	RG-3-300/650-1
MP-120-A		570		3.9	RG-2-400-1
MP-120-B	350	4.2	RG-2-400-1		
MP-120-V	130	30	4.6	RG-2-400-1	
MP-150-A	300	700	20	4.9	RG-3-300/650-1
MP-150-B		500	24	5.0	RG-3-300/650-1
MP-150-V		230	30	5.5	RG-3-300/650-1
MP-240-A		1460	20	6.0	RG-3-300/650-1
MP-240-B		945	24	6.3	RG-3-300/650-1
MP-240-V		515	30	6.8	RG-3-300/650-1

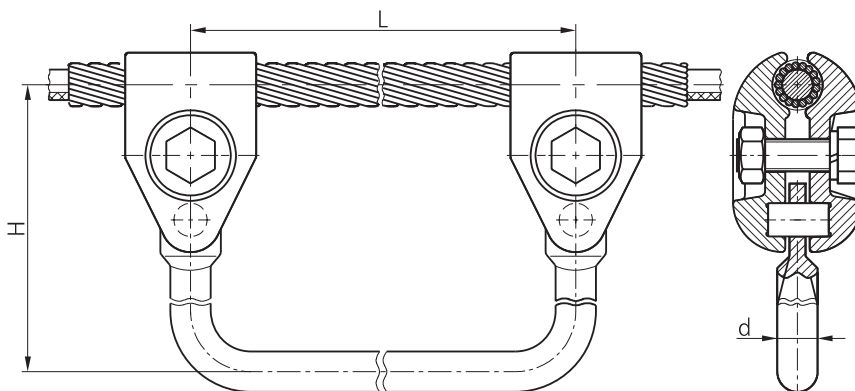

Arcing horns of RR type

Arcing horns of RR type are intended for creating an arcing distance protecting earthwire insulating strings from damage when flash-over occurs. Arcing horns meet TU 3449-157-00111120-99 requirements.

Reference designation	Dimensions, mm			Arcing horns are installed on socket eyes	Weight, kg
	L	H	h		
RR-55	55	256	42	U1-7-16, U2-7-16, U2-12-16, U2-16-20, U2-21-20	0.38
RR-88	88	256	42		0.41
RR-130	130	256	42	U1-12-16, U1-16-20, U2-30-24	0.44
RR-205	205	256	42		0.5
RR-357	357	256	42	US-7-16, US-12-16, U1-21-20	0.61
RR-412	412	256	42		0.66
RR-470	470	256	42	U1-30-24, US-30-24	0.87

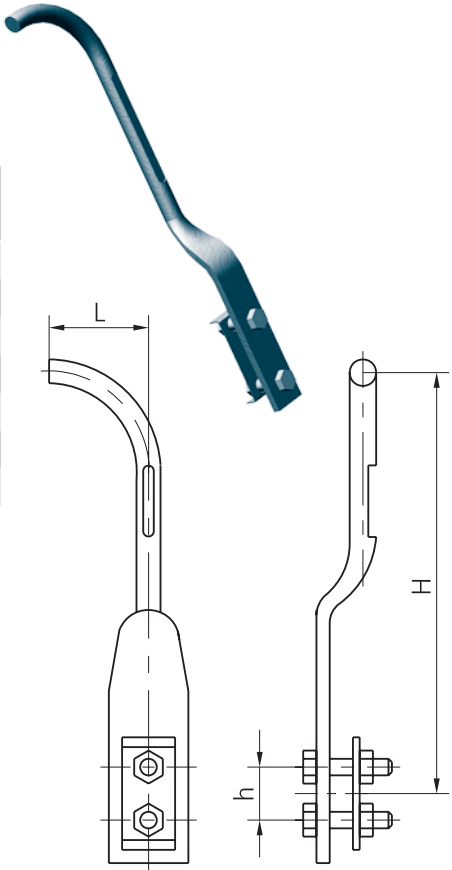

Arcing horns of RR type

Arcing horns of RR type are intended for creating an arcing distance protecting earthwire insulating strings from damage when flash-over occurs. Arcing horns meet TU 3449-157-00111120-99 requirements.

Reference designation	Dimensions, mm			Arcing horns are installed on socket eyes	Weight, kg
	L	H	h		
RR-156	156	230	42	U1-7-16, U2-7-16	0.376
RR-168	168	230	42	U1-12-16, U2-12-16, U1-16-20, U1-21-20, U2-21-20, U2-16-20	0.436
RR-212	212	230	42	U1-30-24, U2-30-24	0.516

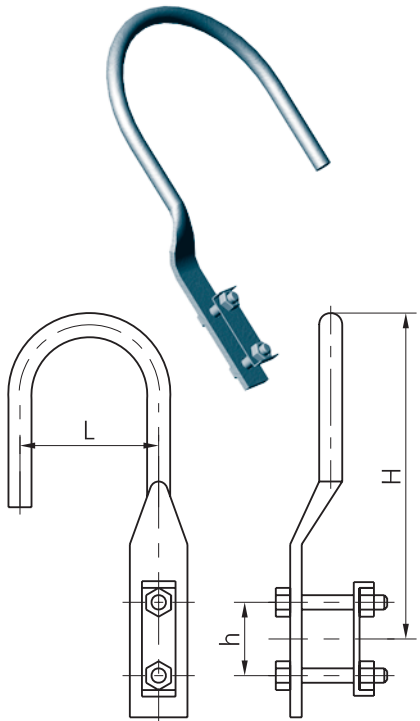

Arcing horns of RRN type

Arcing horns of RRN type are intended for creating an arcing distance protecting earthwire insulating strings from damage when flash-over occurs. Arcing horns meet TU 3449-157-00111120-99 requirements.

Reference designation	Dimensions, mm			Arcing horns are installed on socket eyes	Weight, kg
	L	H	h		
RRN-55	66.5	248	42	U1-7-16, U2-7-16, U2-12-16, U2-16-20, U2-21-20	0.38
RRN-88	99.5	248	42		0.41
RRN-130	141.5	248	42	U1-12-16, U1-16-20, U2-30-24	0.44
RRN-250	261.5	315	42	U1-30-24, U2-30-24, US-30-24, U1-40-28, US-40-28	0.61
RRN-312	323.5	248	42	U1-12-16, U1-16-20, U2-30-24	0.61
RRN-357	368.5	248	42	US-7-16, US-12-16, U1-21-20	0.65
RRN-412	423.5	248	42		0.7
RRN-470	481.5	248	42	U1-30-24, US-30-24	0.78
RRN-940	951.5	248	42		1.27

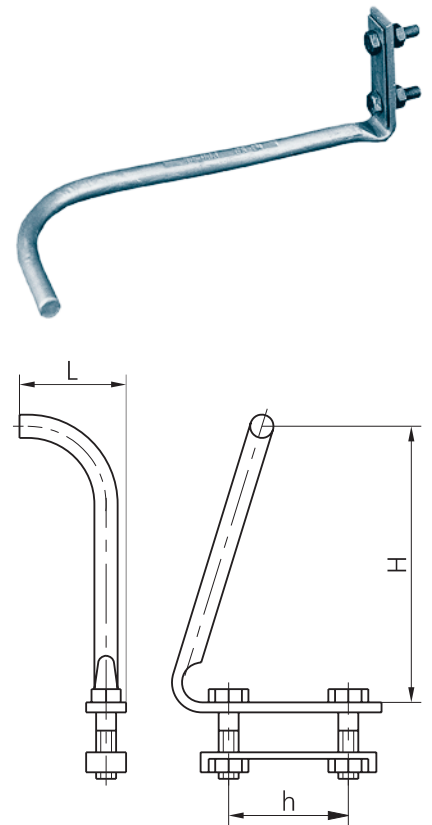

Arcing horns of RRV type

Arcing horns of RRV type are intended for creating an arcing distance protecting earthwire insulating strings from damage when flash-over occurs. Arcing horns are installed on ball eyes. Arcing horns meet TU 3449-157-00111120-99 requirements.

Reference designation	Dimensions, mm			Weight, kg
	L	H	h	
RRV-82	72	256	35	0.54
RRV-95	72	256	35	0.56
RRV-135	92	256	35	0.59
RRV-168	92	256	35	0.62
RRV-198	72	256	35	0.64
RRV-200	92	256	35	0.65
RRV-212	72	256	35	0.66
RRV-342	72	256	35	0.78
RRV-435	72	256	35	0.86
RRV-482	72	256	35	0.94

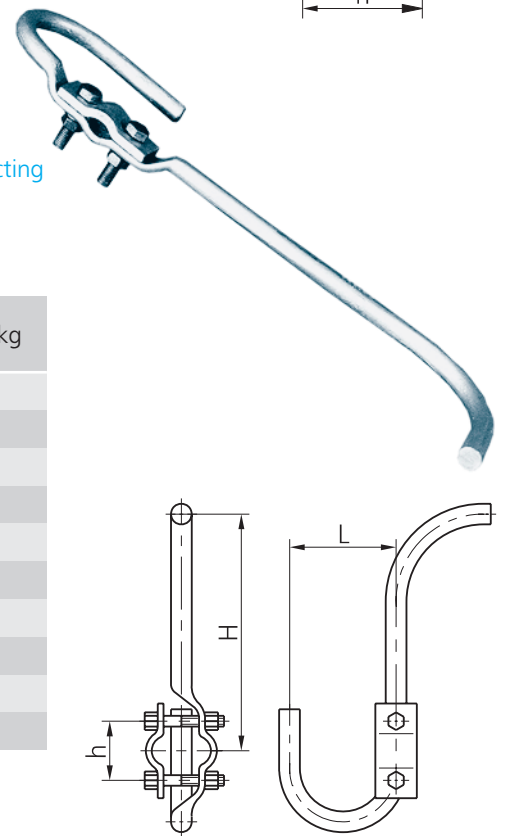

Shield of EO-640/600-1 type

Shield of EO-640/600-1 type is used to reduce radio interference noise.
 Weight – 1.7 kg.
 Shield meet GOST R 51177-98 requirements.

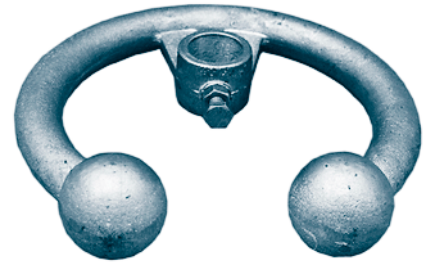
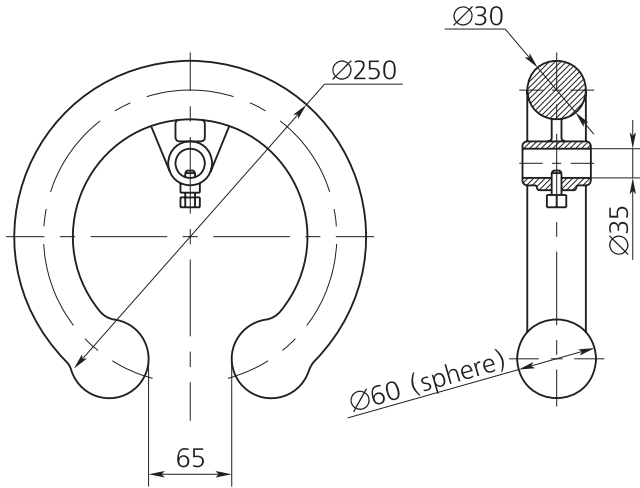

Bolted clamps of PAB type

Bolted clamps of PAB type are intended for hollow conductors (PA-500, PA-640) in substations to prevent their breakage when connected to high-voltage equipment terminals.
 Bolted clamps meet GOST R 51177-98 requirements.

PAB-500-A, PAB-640-A

Reference designation	Dimensions, mm					Weight, kg
	d	D	h	H	L	
PAB-500-A	34	45	65	110	80	1.1
PAB-640-A	34	60	75	130	80	0.98
PAB-500B	34	60	75	130	120	1.95
PAB-640B	34	80	85	150	120	1.95



PAB-500B, PAB-640B

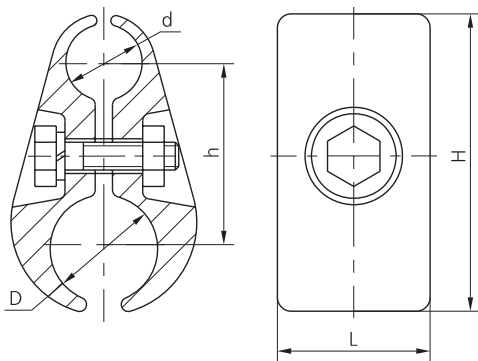

PAB-500-A, PAB-640-A

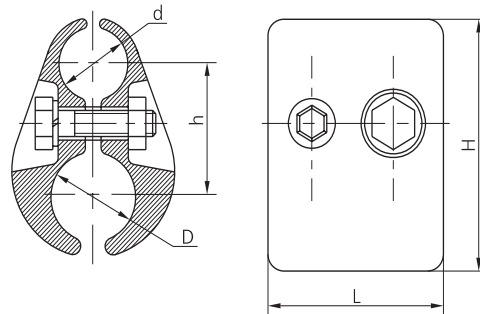

PAB-500B, PAB-640B

Ballast weights

Ballast weights are intended for preventing pulling upward of an insulating string or its considerable deviation from the vertical when exposed to wind. Ballast weights meet TU 3449-162-0011120-99 requirements.

Reference designation	Dimensions, mm			Adjustment steps of ballast weight, kg	Fastening to the clamp	Minimum failing load, kN	Weight, kg
	L	H	D				
BL-100-1	320	313	17	100, 50	PG-1-11, PGN-1-5,	61	103
BL-200-1	480	313	17	200, 150, 100, 50	PGN-2-6, PGN-3-5	62	205
BL-400-1	732	386	17	400, 300, 200, 100	PGN-1-5, PGN-2-6, PGN-3-5	29	411

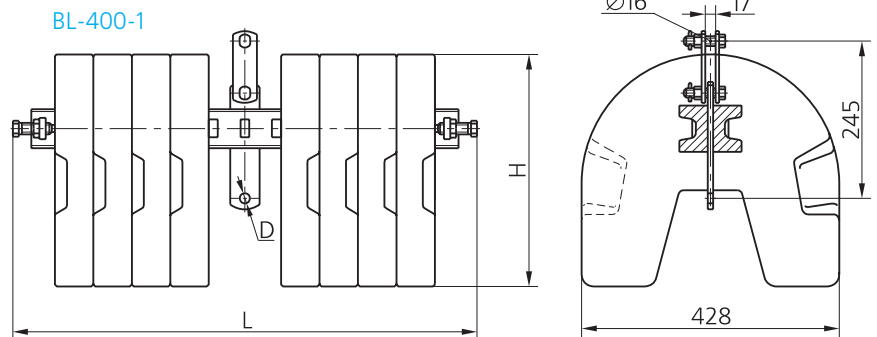
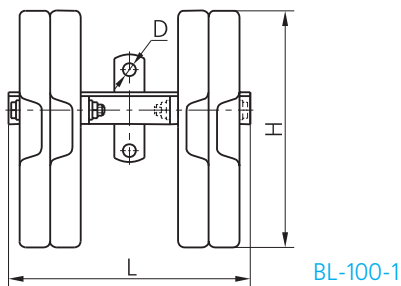
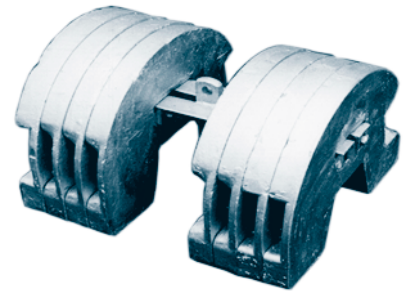
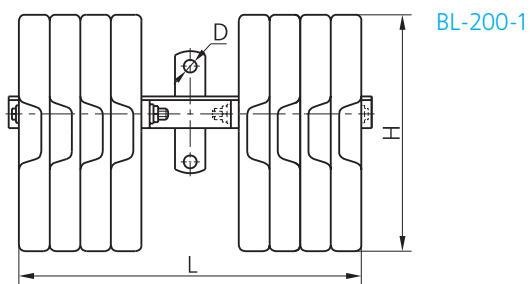

Ballast weight of BL-400-5 type

Ballast weight of BL-400-5 type is intended to prevent tightening up of the insulating set (with the suspension clamp of PGN-5-3 type) and huge lack of perpendicularity under the wind.

Adjustment steps of ballast weight – 400, 300, 200, 100 kg.

Minimum failing load – 64 kN.

Weight – 415.6 kg.

Ballast weight meet TU 3449-162-0011120-99 requirements.

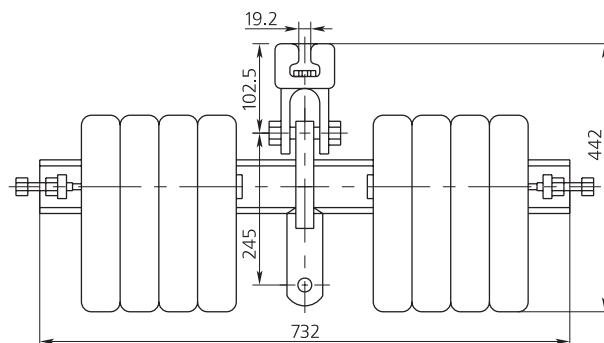
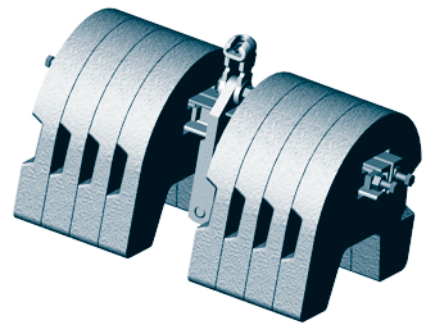

Ballast weights to suspension clamps for two and three conductors

Ballast weights are intended for preventing pulling upward of an insulating string or its considerable deviation from the vertical when exposed to wind. Ballast weights meet TU 3449-162-0011120-99 requirements.

Reference designation	l_{max} , mm	A, mm	Adjustment steps of ballast weight, kg	Fastening to the clamp	Weight, kg
2BL-800-3	858	112	from 800 to 400 via 100 kg	2PGN-5-7 3PGN-5-7	815
3BL-1400-1	1322	96	from 1400 to 800 via 100 kg	2PGN-5-7 3PGN-5-7	1422

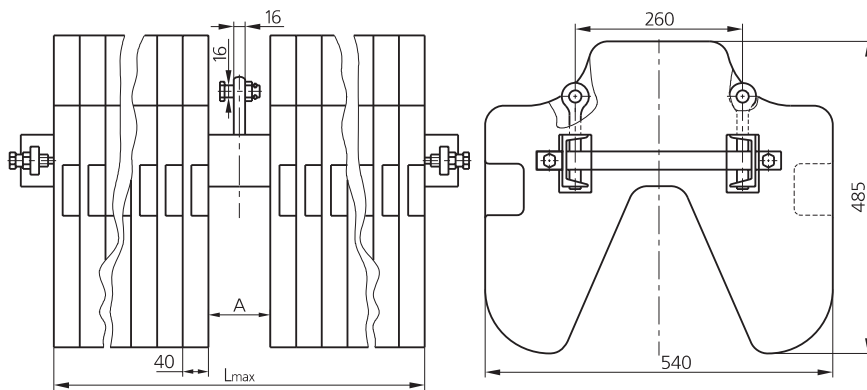

Attachment fitting for shield of UKE-1A type

Attachment fittings for shield UKE-1A are used on 330–1150 kV power transmission lines.

Weight – 29.0 kg.

Attachment fittings meet TU 3449-006-40064547-2001 requirements.

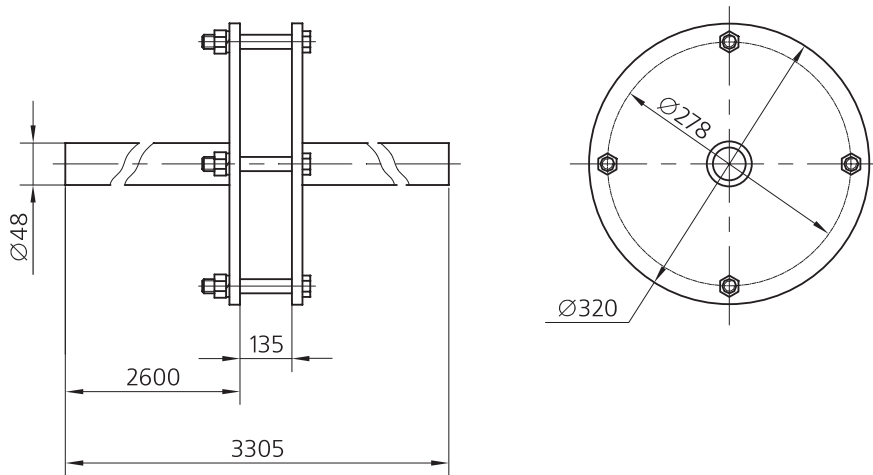

Attachment fitting for shield of UKE-1B type

Attachment fittings for shield UKE-1B are used on 330–1150 kV power transmission lines.

Weight – 8.4 kg.

Attachment fittings meet TU 3449-006-40064547-2001 requirements.

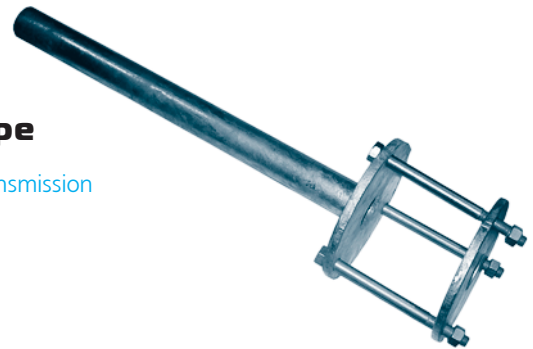
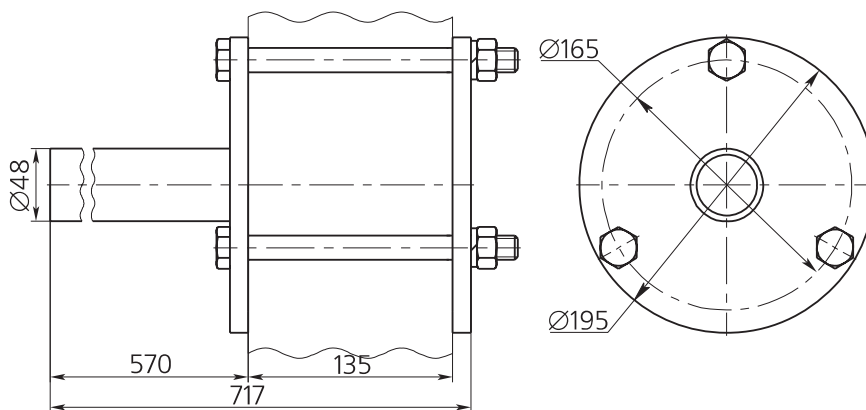

Thimble clevis wedged tension clamps of NKK type

Thimble clevis wedged tension clamps of NKK type are intended for fastening steel-aluminum conductor with sectional view from 10 to 50 mm² and steel-wire rope with sectional view from 25 to 86 mm² to tension strings of anchor and anchor and angle tension towers of transmission lines. Tension clamps meet TU 3449-131-00111120.

Reference designation	Wedged number	Conductors with GOST 839-80		Earthwire diameter, mm			Minimum failing load, kN	Weight, kg
		Nominal section, mm ²	Conductor diameter, mm	GOST 3062-80	GOST 3063-80	GOST 3071-88		
NKK-1-1B	1	10/1.8	4.5	—	—	—	60	0.8
		16/2,7	5.6	—	—	—		
		25/4.2	6.9	—	—	—		
		35/6.2	8.4	—	—	—		
		50/8.0	9.6	—	—	—		
	2	—	—	—	6.8	6.6		—
		—	—	—	7.4	7.1		—
		—	—	—	8.0	7.6		—
		—	—	—	8.6	8.1		—
		—	—	—	9.2	8.6		—
NKK-2-1	—	—	—	—	11.0	13.5	120	3.1

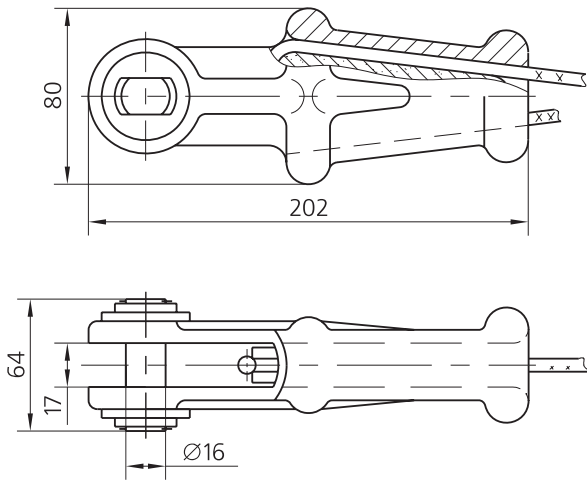

NKK-1-1B

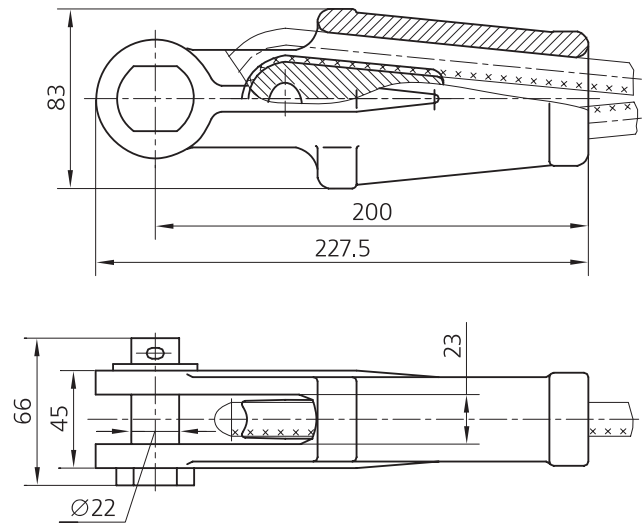

NKK-2-1

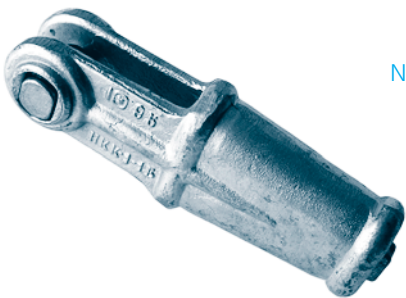

Wedged tension clamp of NK-1-1 type

Wedged tension clamp of NK-1-1 type is intended for fastening aluminum and copper conductors with sectional view from 16 to 95 mm² to tension strings of anchor and anchor and angle tension towers of transmission lines. Depends on conductors brand, clamp has to be completed by appropriate wedge.

Reference designation	Wedged number	Conductors with GOST 839-80	Minimum failing load, kN	Weight, kg
NK-1-1	1	A16, A25	43.9	1.0
	1A	M16, M25		1.2
	2	A25, A50		1.0
	2A	M35, M50		1.2
	3	A70, A95		1.0
	3A	M70, M95		1.2

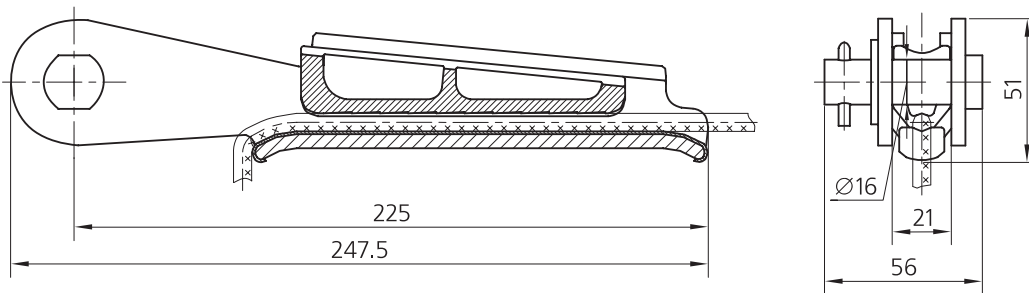

**Tension clamp of NB-1 type
intended for conductors and earthwires of 5.6 mm...13.5 mm diameter**

Tension clamp of NB-1 type is intended for fastening and holding in tension conductors and earthwires of 5.6 mm...13.5 mm diameter of overhead power lines.
Minimum failing load – 40 kN.
Weight – 0.55 kg.
Tension clamp meet GOST R 51177-98 requirements.

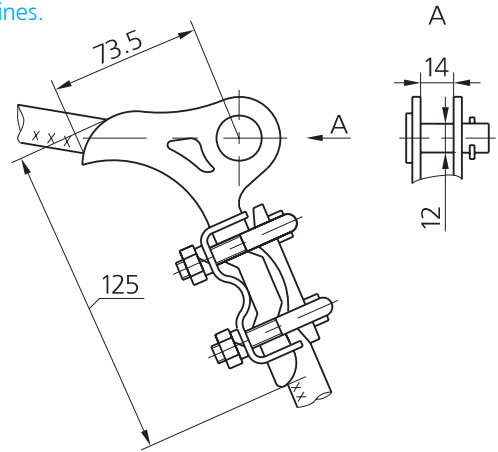

**Tension clamp of NB-2-6 type
intended for conductors and earthwires of 11.4 mm...17.1 mm diameter**

Tension clamp of NB-2-6 type is intended for fastening and holding in tension conductors and earthwires of overhead power lines.
Minimum failing load – 57 kN.
Weight – 1.85 kg.
Tension clamp meet TU 3413.11310-88 requirements.

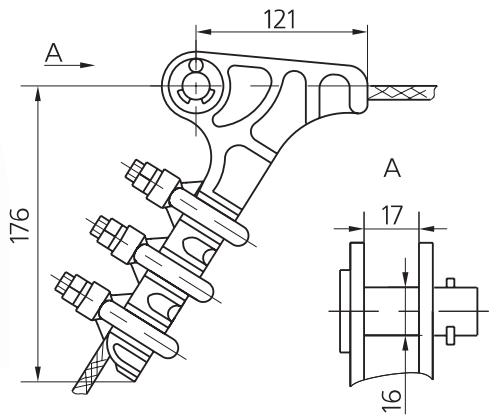

Tension clamp of NB-3-6B type intended for conductors of 15.8 mm...22.1 mm diameter

Tension clamp of NB-3-6B type is intended for fastening and holding in tension conductors and earthwires of overhead power lines.

Minimum failing load – 90 kN.

Weight – 4.7 kg.

Tension clamp meet TU 3413.11310-88 requirements.

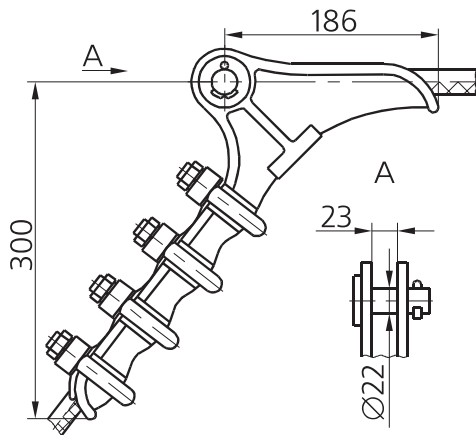

Wedge-operated tension clamp of NZ-2-7 type

Wedge-operated tension clamp of NZ-2-7 type is intended for fastening conductors (aluminium, steel-aluminium, copper) of 11.4 mm...17.1 mm diameter.

Minimum failing load – 57 kN.

Weight – 2.1 kg.

Tension clamp meet TU 3413.11310-88 requirements.

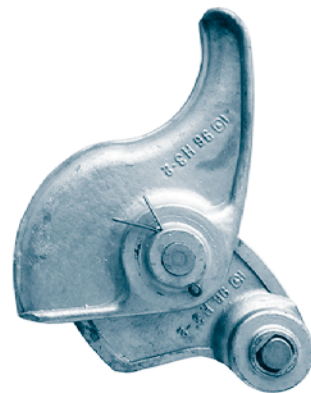
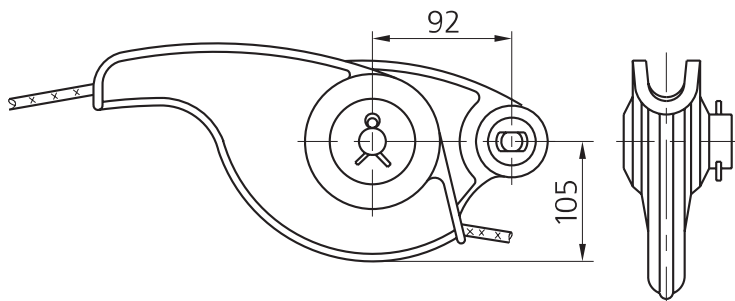

Compression tension clamps of NAS type

Compression tension clamps of NAS type are used for mounting steel-aluminium wires. Tension clamps meet TU 3413.11419-89 requirements.

Reference designation	Dimensions, mm					Weight, kg	Steel-aluminium conductors			Wire dressing strength, kN	Minimum failing load, kN
							Nominal section (aluminum/steel), mm ²	Diameter, mm			
	d	b	L	L1	L2			wire	core		
NAS-240-1	23	22	350	100	185	2.5	185/24	18.9	6.3	58.07	84.4
							185/29	18.8	6.9	62.05	
							205/27	19.8	6.6	63.74	
							240/32	21.6	7.2	75.05	
NAS-240-2	23	22	350	100	185	2.48	240/39	21.6	8.0	80.89	91
							185/43	19.6	8.4	77.76	
NAS-330-1	23	22	360	110	195	2.73	240/56	22.4	9.6	98.25	116.7
							300/39	24.0	8.0	90.57	
							300/48	24.1	8.9	100.6	
							300/43	25.2	8.4	103.78	
NAS-330-2	23	22	360	110	195	2.75	330/30	24.8	6.9	88.84	100
NAS-300-1	26	25	385	110	195	3.2	300/66	24.5	10.5	117.5	142
							300/67	24.5	10.5	126.2	
NAS-400-1	23	22	400	120	225	3.07	400/18	26.0	5.6	85.60	107
							400/22	26.6	6.0	95.11	
							400/51	27.5	9.2	120.4	
NAS-450-1	26	25	415	120	225	3.5	400/64	27.7	10.2	129.1	147.7
							450/56	28.8	9.6	131.3	
							500/26	30.0	6.6	112.1	
NAS-500-1	26	25	425	120	225	3.26	500/27	29.4	6.6	112.5	126.6
							400/93	29.1	12.5	173.7	
NAS-600-1	29	28	495	140	285	5.3	500/64	30.6	10.2	148.2	206.8
							550/71	32.4	10.8	166.1	
							600/72	33.2	11.0	183.8	
							650/79	34.7	11.5	200.4	
NAS-700-1	34	32	540	150	310	7.4	700/86	36.2	12.0	217.7	244.9
							750/93	37.7	12.5	234.4	
NAS-800-1	38	36	545	150	310	7.47	800/105	39.7	13.3	260.0	292.5
							800/105	39.7	13.3	260.0	
NAS-1200-1A	38	36	635	200	400	8.85	1200/67	—	—	—	266.2

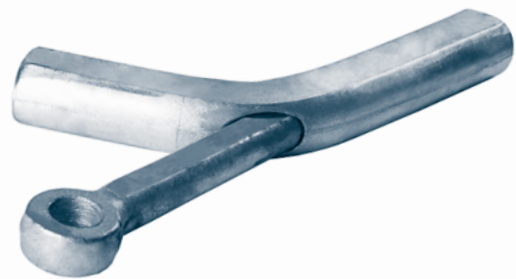
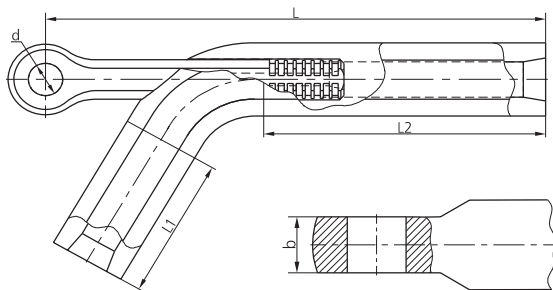

Compression tension clamps of NAS type

Compression tension clamps of NAS type are intended for application in the transmission lines which are placed in the areas with annual temperature of -10°C and lower or in areas with the lowest temperature of -50°C and lower (Northern areas).

Tension clamps meet TU 3413.11419-89 requirements.

Reference designation	Dimensions, mm					Weight, kg	Steel-aluminium conductors				Wire dressing strength, kN	Minimum failing load, kN
							Nominal section (aluminum/steel), mm^2	Diameter, mm		Breaking load, kN		
	d	b	L	L1	L2			wire	core			
NAS-240-1.1	23	22	350	100	185	2.43	185/24	18.9	6.3	58.07	55.18	88.668
							185/29	18.8	6.9	62.05	58.95	97.737
							205/27	19.8	6.6	63.74	60.55	100.390
							240/32	21.6	7.2	75.05	71.30	118.203
NAS-240-2.1	26	25	355	100	185	2.5	240/39	21.6	8.0	80.89	76.85	127.410
							185/43	19.6	8.4	77.76	73.87	122.483
NAS-330-1.1	26	25	365	110	195	2.75	240/56	22.4	9.6	98.25	93.34	154.749
							300/39	24.0	8.0	90.57	86.05	142.654
							300/48	24.1	8.9	100.62	95.57	158.481
							330/43	25.2	8.4	103.78	98.59	163.460
NAS-330-2.1	26	25	365	110	195	2.73	330/30	24.8	6.9	88.84	84.40	139.936
NAS-300-1.1	29	28	390	110	195	3.24	300/67	24.5	10.5	126.2	111.64	185.094
							300/66	24.5	10.5	117.5	120.00	198.876
NAS-400-1.1	26	25	405	120	225	3.07	400/18	26.0	5.6	85.60	81.32	134.820
							400/22	26.6	6.0	95.11	90.35	149.806
NAS-450-1.1	29	28	420	120	225	3.54	400/51	27.5	9.2	120.4	114.45	189.757
							400/64	27.7	10.2	129.1	122.72	203.449
							450/56	28.8	9.6	131.3	124.80	206.907
							500/26	30.0	6.6	112.1	106.92	176.659
NAS-500-1.1	29	28	430	120	225	3.31	500/27	29.4	6.6	112.5	106.58	177.262
NAS-500-2.1	34	32	500	140	285	5.49	500/64	30.6	10.2	148.26	165.03	233.505
NAS-600-1.1	38	36	500	140	285	5.58	400/93	29.1	12.5	173.7	157.80	273.600
							550/71	32.4	10.8	166.1	140.80	261.708
							600/72	33.2	11.0	183.8	174.60	289.540
NAS-700-1.1	40	38	545	150	310	7.87	650/79	34.7	11.5	200.4	190.43	315.710
							700/86	36.2	12.0	217.7	206.89	342.996
NAS-800-1.1	42	40	555	150	310	8.02	750/93	37.7	12.5	234.4	222.73	369.258
							800/105	39.7	13.3	260.0	247.07	409.615

Compression tension clamps of NAS-M type

Compression tension clamps of NAS-M type is intended for fastening steel-aluminum compact conductors of ACk2u type in compliance with TU 16.K03-53 standard to the tension string of overhead transmission lines.

Tension clamps meet TU 3449-278-76935199-2014 requirements.

Reference designation	Conductors ACk2u according to TU 16.K03-53							Breaking load, kN, not less than	Conductor dressing strength, kN, not less than	Factored load of clamp, kN, not less than	Weight, kg, not more than
	b	d	L	L1	L2	Diameter, mm	Nominal section, mm ²				
NAS-240M	25	26	375	120	205	19.6	240/39	97.303	92.438	153.25	2.7
NAS-300M	28	29	375	120	205	21.5	300/39	106.350	101.032	167.50	2.9
NAS-300M-2	32	34	450	150	260	22.5	300/66	150.900	143.355	237.66	3.7
NAS-330M	28	29	420	120	225	22.6	330/43	117.150	111.292	184.51	3.2
NAS-450M	28	29	425	130	230	24.8	400/51	140.150	133.142	157.67	3.3
NAS-500M	32	34	505	150	310	27.8	500/64	175.600	166.820	197.55	4.2

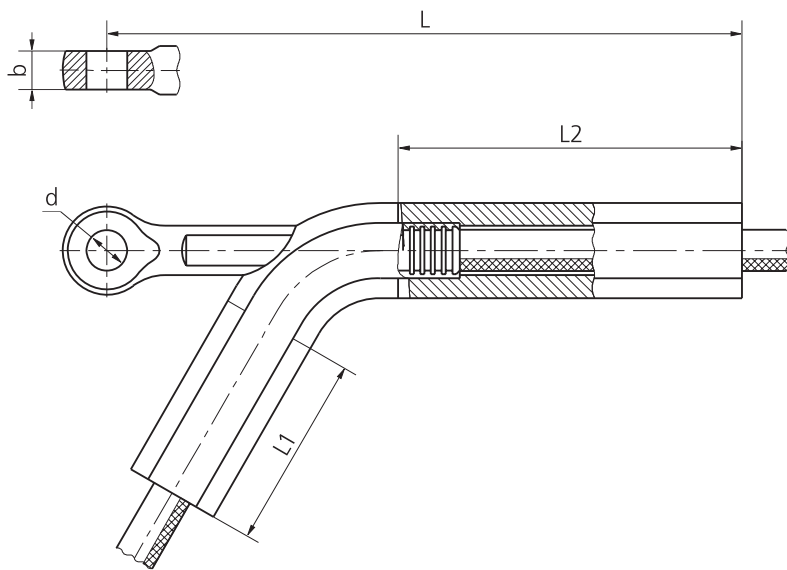

Transposition tension clamps of TRAS type

Transposition tension clamps of TRAS type are intended for transpositioning wires on the tower. Tension clamps meet TU 3413.11419-89 requirements.

Reference designation	Dimensions, mm					Weight, kg	Steel-aluminium conductors			Wire dressing strength, kN	Minimum failing load, kN
							Nominal section (aluminum/steel), mm ²	Diameter, mm			
	d	b	L	L1	L2			wire	core		
TRAS-240-1	23	22	350	100	185	2.5	185/24	18.9	6.3	58.07	84.4
							185/29	18.8	6.9	62.05	
							205/27	19.8	6.6	63.74	
							240/32	21.6	7.2	75.05	
TRAS-240-2	23	22	350	100	185	2.48	240/39	21.6	8.0	80.89	91.0
							185/43	19.6	8.4	77.76	
TRAS-330-1	23	22	360	110	195	2.73	240/56	22.4	9.6	98.25	116.7
							300/39	24.0	8.0	90.57	
							300/48	24.1	8.9	100.62	
							300/43	25.2	8.4	103.78	
TRAS-330-2	23	22	360	110	195	2.75	330/30	24.8	6.9	88.84	100.0
TRAS-300-1	26	25	385	110	195	3.2	300/66	24.5	10.5	117.5	142.0
							300/67	24.5	10.5	126.2	
TRAS-400-1	23	22	390	120	225	3.07	400/18	26.0	5.6	85.60	107.0
							400/22	26.6	6.0	95.11	
							400/51	27.5	9.2	120.4	
TRAS-450-1	26	25	405	120	225	3.5	400/64	27.7	10.2	129.1	147.7
							450/56	28.8	9.6	131.3	
							500/26	30.0	6.6	112.1	
TRAS-500-1	26	25	415	120	225	3.26	500/27	29.4	6.6	112.5	126.6
							400/93	29.1	12.5	173.7	
TRAS-600-1	29	28	495	140	285	5.3	500/64	30.6	10.2	148.2	206.8
							550/71	32.4	10.8	166.1	
							600/72	33.2	11.0	183.8	
							650/79	34.7	11.5	200.4	
TRAS-700-1	34	32	540	150	310	7.4	700/86	36.2	12.0	217.7	244.9
							750/93	37.7	12.5	234.4	
TRAS-800-1	38	36	545	150	310	7.47	800/105	39.7	13.3	260.0	292.5
							800/105	39.7	13.3	260.0	
TRAS-1200-1A	38	36	635	200	400	8.85	1200/67	—	—	—	266.2

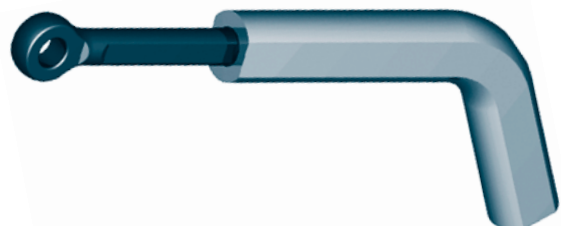
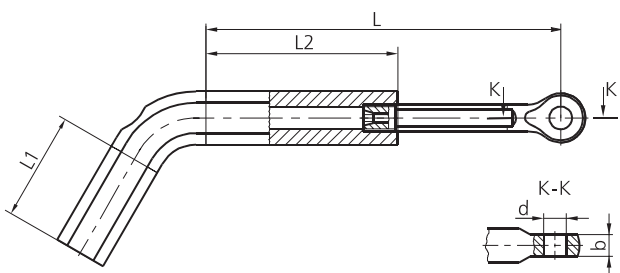

Compression tension clamps of NS type

Compression tension clamps of NS type are intended for fastening to anchor supports of steel rope used as the lighting protection rope on power transmission lines.

Tension clamps meet TU 3449-003-40064547-2001 requirements.

Reference designation	Dimensions, mm							Weight, kg	Steel ropes		Rope dressing strength, N	Minimum failing load, N
	B	B1*	d	D	L	L1	L2		Diameter, d1, mm	Breaking load, N		
NS-50-3	55	18.7	18	26	285	62	120	1.20	9.2	63650	60467	90375
									9.1	59950	56952	
									9.2	57450	54577	
									9.8	72300	68685	
NS-70-3	64	23.7	20	30	320	65	150	1.68	11.0	89950	85452	126250
									11.5	101000	95950	
									11.5	87000	82650	
NS-100-3	77	28.7	24	34	355	81	165	2.61	12.5	109500	104025	155625
									13.0	124500	118275	
NS-120-3	82	29.7	26	36	405	84	190	3.40	14.0	145500	138225	181875
									14.0	135500	128725	
NS-140-3	82	29.7	26	36	405	84	190	3.33	15.0	166500	158175	208125
									15.5	164000	155800	
NS-150-3	89	32.7	28	42	435	92	210	4.52	16.0	189500	180025	236875
									17.0	214000	203300	
NS-170-3	91	34.7	28	42	435	92	210	4.45	17.0	195500	185725	267500
									18.5	229500	218025	
NS-220-3	107	38.7	34	48	485	106	240	6.74	19.0	267500	254125	333750
									20.0	266500	253175	
NS-230-3	107	38.7	34	48	485	106	240	6.66	21.0	305500	290225	381875
NS-260-3	109	40.7	34	53	530	111	280	7.96	22.5	347000	329650	433750
NS-300-3	116	43.7	36	53	540	119	280	8.65				

* not less than

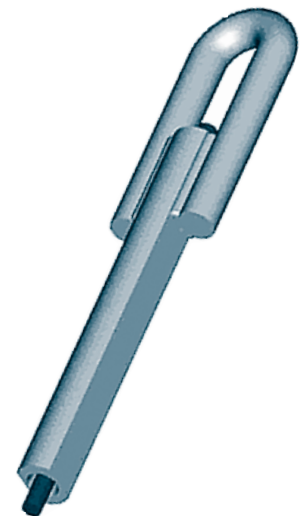
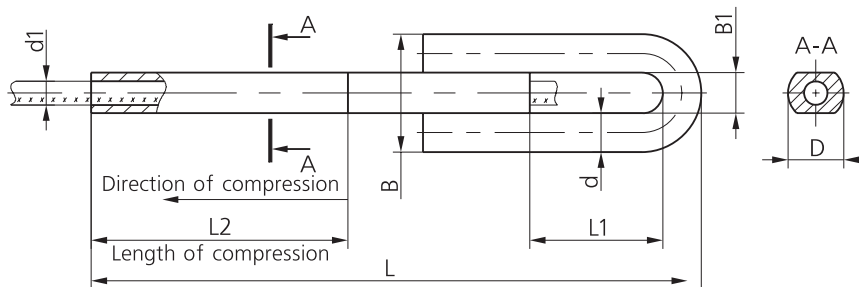

Compression tension clamps of NS type

Compression tension clamps of NS type are intended for application in the transmission lines which are placed in the areas with annual temperature of -10°C and lower or in areas with the lowest temperature of -50°C and lower (Northern areas).

Tension clamps meet TU 3449-003-40064547-2001 requirements.

Reference designation	Dimensions, mm							Weight, kg	Steel ropes		Rope dressing strength, N	Minimum failing load, N
	B	B1*	d	D	L	L1	L2		Diameter, d1, mm	Breaking load, N		
NS-50-3.1	55	18.7	18	26	285	62	120	1.20	9.2	63650	60467	111388
									9.1	59950	56952	
									9.2	57450	54577	
NS-50-3.2	64	23.7	20	30	290	65	120	1.42	9.8	72300	68685	126525
NS-70-3.1	64	23.7	20	30	320	65	150	1.68	11.0	89950	85452	157413
									11.5	87000	82650	
NS-70-3.2	77	28.7	24	34	340	81	150	2.01	11.5	101000	95950	176750
NS-100-3.1	77	28.7	24	34	355	81	165	2.60	12.5	109500	104025	217875
									13.0	124500	118275	
NS-120-3.1	82	29.7	26	36	405	84	190	3.40	14.0	145500	138225	254625
									14.0	135500	128725	
NS-140-3.2	86	29.7	28	36	410	87	190	3.55	15.0	166500	158175	291375
									15.5	164000	155800	
NS-150-3.2	97	32.7	32	42	440	93	210	5.0	16.0	189500	180025	331625
NS-170-3.2	99	34.7	32	42	450	103	210	5.2	17.0	214000	203300	374500
									17.0	195500	185725	
NS-220-3.1	107	38.7	34	48	485	106	240	6.74	18.5	229500	218025	468125
									19.0	267500	254125	
NS-230-3.1	107	38.7	34	48	485	106	240	6.66	20.0	266500	253175	466375
NS-260-3.1	113	40.7	36	53	535	114	280	8.3	21.0	305500	290225	534624
NS-300-3.2	120	43.7	38	53	545	122	280	9.0	22.5	347000	329650	607250

* not less than

Wedge-type tension clamps of ZNK type

Wedge-type tension clamps of ZNK type are intended for mounting aluminum and steel-aluminum conductors with the diameter of 21.6 mm...30.6 mm.

Reference designation	Dimensions, mm							Weight, kg, not more than	Conductor AC with GOST 839-80			Conductor dressing strength, kN, not less than	Minimum failing load, kN
	B	d	L	L _{1max}	B1	H1	H		Nominal section, mm ²	Diameter, mm	Breaking load, kN, not less than		
ZNK-30-3AC	29	28	545	804	104	130	180	14.1	450/56	28.8	131.370	124.81	195.43
									400/93	29.1	173.715	165.03	
									500/26	30.0	112.548	106.93	
									500/34.6	30.09	119.407	113.44	
									500/64	30.6	148.257	140.85	
ZNK-30-2AC	26	25	545	804	104	130	180	13.1	400/22	26.6	95.115	90.36	138.08
									400/27.7	26.91	98.356	93.44	
									400/51	27.5	120.481	114.46	
									400/64	27.7	129.183	122.73	
ZNK-20-2AC	26	25	378	560	99	108	118	6.8	315/21.8	23.83	79.030	75.08	134.96
									300/39	24.0	90.574	86.05	
									300/48	24.1	100.623	95.59	
									300/66	24.5	117.520	111.65	
									300/67	24.5	126.270	119.96	
									330/30	24.8	88.848	84.41	
									315/51.3	24.87	106.834	101.50	
ZNK-20-1AC	23	22	378	560	99	108	118	7.4	240/32	21.6	75.050	71.30	110.54
									240/39	21.6	80.895	76.85	
									240/56	22.4	98.253	93.34	

Reference designation	Dimensions, mm							Weight, kg, not more than	Conductor of AAAC-Z according to TU 3510-001-699 48333			Conductor dressing strength, kN, not less than	Minimum failing load, kN
	B	d	L	L _{1max}	B1	H1	H		Nominal section, mm ²	Diameter, mm	Breaking load, kN, not less than		
ZNK-30-3A	29	28	545	790	104	130	180	15	461.73	26.1	150.06	142.56	168.82

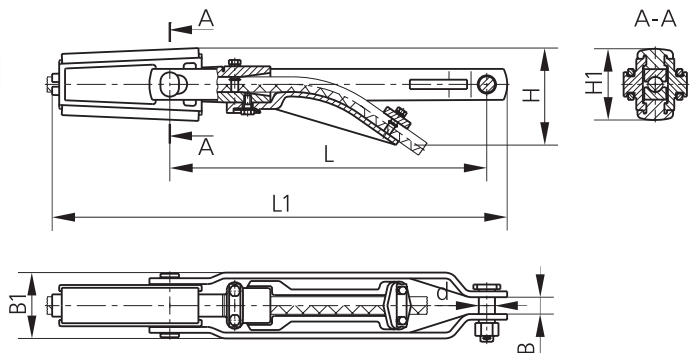
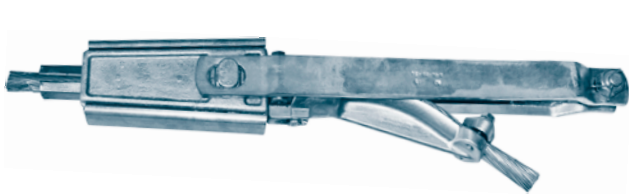

Connectors of SVS type

Connectors of SVS type are intended for connecting earthwires.
 Connectors of SVS type ensure a holding force not less than 90% of the ultimate strength of the earthwire.
 Connectors meet TU 3449-130-0011120-97 requirements.

Reference designation	Earthwire diameter, mm	Pressing matrix	Dimensions, mm			Weight, kg
			d	D	L	
SVS-50-3	9.1...9.2	MSH-22.5	14.5	26	80	0.22
SVS-70-3	11	MSH-26	17.5	30	85	0.3
SVS-100-3	13	MSH-31.2	21	36	90	0.47
SVS-120-3	14	MSH-33.8	22.5	40	95	0.64
SVS-135-3	15	MSH-34.6	24	40	100	0.63
SVS-150-3	16	MSH-36.4	25.5	42	110	0.75
SVS-200-3	18.5	MSH-41.1	29.5	48	120	1.05
SVS-260-3	21	MSH-48	33.5	56	120	1.4
SVS-300-3	22.5	MSH-52	34	60	120	1.7

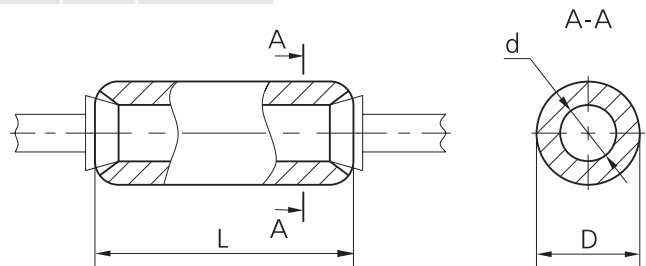
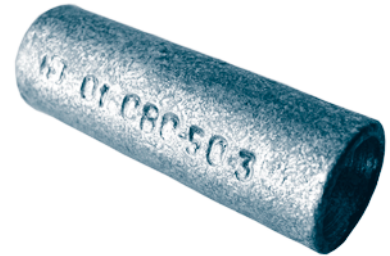

Bolted coupling clamps of PS type

Bolted coupling clamps of PS type are intended for earthing of earthwires in 35–110 kV power lines.
 Clamps meet TU 3449-115-0011120-95 requirements.

Reference designation	Earthwire diameter, mm	Dimensions, mm			Earthwire dressing strength, kN	Weight, kg
		A	L	M		
PS-1-1	5.5...8.6	28	70	36	2.5	0.373
PS-2-1	9.1...12.0	34	70	36	2.5	0.42
PS-3-1	12.5...14.0	34	92	42	2.5	0.75

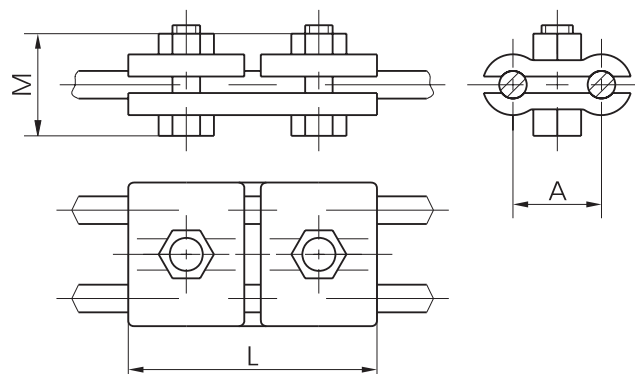
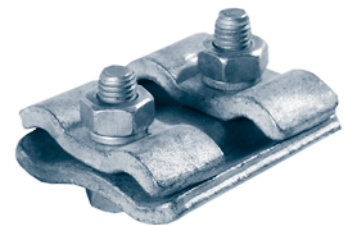

Compression type earthing clamps

Compression type earthing clamps are intended for connecting earthwires to earthing terminals of power line towers and to suspension clamps of earthwires. Clamps meet TU 3449-125-00111120-97 requirements.



Reference designation	Dimensions, mm		Weight, kg	Earthwires		
	I	L		GOST	Cross-section area, mm ²	Diameter, mm
ZPS-35-3	82	102	0.276	3064	35.34	7.8
ZPS-50-3	91	111	0.337	3063	48.64	9.1
				3064	49.32	9.2
				3062	50.45	9.8
				3062	57.33	11
ZPS-70-3	105	125	0.489	3063	72.95	11.5
				3064	74.65	12.5
				3062	80.61	13
ZPS-100-3	117	137	0.69	3064	94.44	14
				3063	101.72	15
ZPS-120-3	128	148	0.84	3064	116.89	15.5
				3063	117.9	16
ZPS-140-3	148	168	0.94	3063	135.28	17
				3064	141.37	18.5
ZPS-150-3	—	171	1.03	3063	153.84	19
ZPS-170-3	—	191	1.45	3064	168.17	20
				3063	173.6	21
ZPS-220-3	—	199	1.99	3064	197.29	22.5
				3063	216.7	24
ZPS-230-3	—	204	2.03	3064	228.74	27
ZPS-260-3	—	211	2.59	3064	262.51	
ZPS-300-3	—	216	2.63	3064	298.52	
ZPS-340-3	—	223	3.01	3064	337.03	
ZPS-420-3	212	232	4.27	3064	420.84	

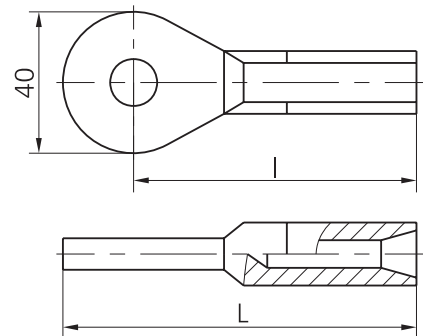

Bolted coupling clamps of PA type

Bolted coupling clamps of PA type are intended for connecting aluminium and steel-aluminium wires on power lines of from 10 to 185 mm² cross section in anchor tower eyes.

Clamps meet TU 3449-115-0011120-95 requirements.

Reference designation	Conductor diameter, mm	Dimensions, mm						Weight, kg
		A	B	L	I	R	H	
PA-1-4	5.1...8.4	20	30	52	23	4.0	36	0.12
PA-2-4	9.6...11.4	30	46	60	32	6.0	47	0.24

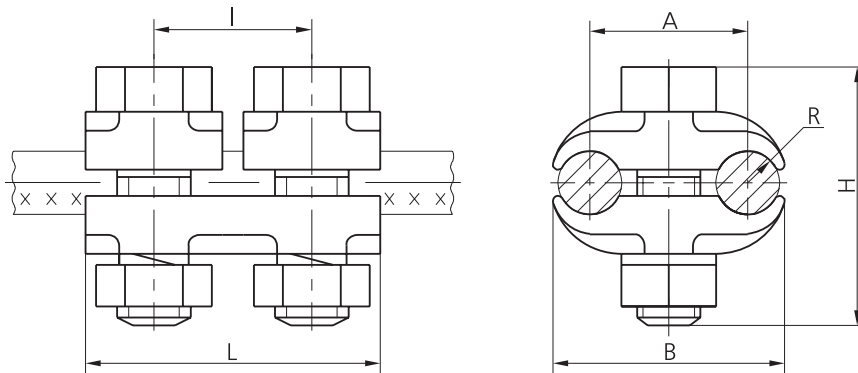

Compression coupling clamps of SAS type for steel-aluminium wires

Compression coupling clamps of SAS type for steel-aluminium wires. Clamps meet TU 3449-005-40064547 requirements.

Reference designation	Dimensions, mm			Wire dressing strength, kN	Wire diameter, mm	Minimum failing load, kN	Weight, kg
	L	l	D				
SAS-240-1	540	80	52	52.2	—	—	2.33
				55.8	—		
				57.3	—		
				67.5	—		
SAS-240-2	540	80	52	72.8	—	—	2.33
				69.9	—		
SAS-240-3	540	80	52	88.4	—	—	2.33
SAS-300-1	580	90	54	111.64	24.5	142.0	2.83
				119.96	24.5		
SAS-330-1	580	80	54	81.5	—	—	2.44
				90.5	—		
				93.4	—		
SAS-400-1	580	80	54	79.9	—	—	2.44
				77.0	—		
				85.6	—		
SAS-400-2	660	90	58	165.03	29.1	195.4	3.46
SAS-500-1	660	80	58	114.45	27.5	147.7	3.32
				122.72	27.7		
				124.80	28.8		
SAS-500-2	660	80	58	106.92	29.4	126.6	3.33
				106.58	30.0		
SAS-600-1	750	90	65	157.85	32.4	206.8	4.53
				174.64	33.2		

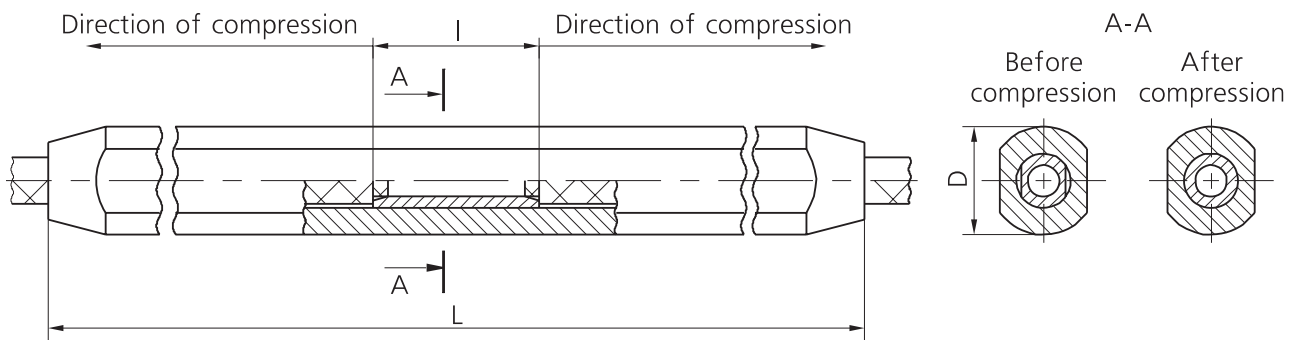

Corrosionproof automatic connectors

Corrosionproof automatic connectors with the color code for easier identification (produced by MacLean Power) are intended for fastening steel-aluminum conductors of AC type according to GOST 839-80 and conductors of ACSR, AAAC, AAC.

Type of connectors	ACSR ASTM-B232	AAAC ASTM-B399	AAC ASTM-B231	Nominal section and diameter of the conductors according to GOST 839-80, mm ² (mm)	A, mm	B, mm	Colour code	D, mm
7654AP-CRS	1/0, 2/0	1/0, 2/0	1/0, 2/0, 3/0	50/8.0 (9.6)	406.4	32.26	grey/yellow	9.27–12.07
				63/10.5 (10.97)				
				70/11 (11.4)				
7658AP-CRS	266.8–18/1, 336.4–18/1	266.8, 336.4	266.8, 336.4, 397.5	70/72 (15.4)	546.1	46.99	green/brown	14.73–18.39
				120/19 (15.2)				
				120/27 (15.4)				
				125/6.9 (14.67)				
				125/20.4 (15.67)				
				150/19 (16.8)				
				150/24 (17.1)				
				150/34 (17.5)				
				160/8.9 (16.82)				
				160/26.1 (17.73)				
				7659-CRS				
185/29 (18.8)								
185/43 (19.6)								
200/11.1 (18.81)								
200/32.6 (19.82)								
205/27 (19.8)								
240/32 (21.6)								
240/39 (21.6)								
7660-CRS	556.5–18/1, 795.0–36/1	556.5–636.0	636–795.0	240/56 (22.4)	596.9	59.44	natural	22.33–26.42
				300/39 (24.0)				
				300/48 (24.1)				
				300/66 (24.5)				
				300/67 (24.5)				
				315/21.8 (23.83)				
				315/51.3 (24.87)				
				330/30 (24.8)				
330/43 (25.2)								

Corrosionproof automatic connectors

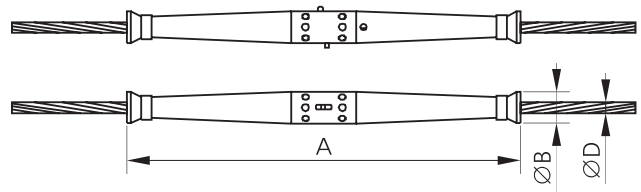

Screwed pin

Screwed pin are intended for the line fittings in overhead transmission lines.
Screwed pin meet TU 3449-147-0011120-98 requirements.

Reference designation DxL, mm	Dimensions, mm						
	D	L	d	d1	l	S	H
10xL	10	50; 55; 60; 65; 70; 75; 80; 85; 90; 95; 100; 105; 110; 115; 120; 125; 130; 135; 140; 145; 150; 155; 160; 165; 170; 175; 180; 185; 190; 195; 200; 205; 210; 215; 220; 225; 230; 235; 240; 245; 250; 255; 260; 265; 270; 275; 280; 285; 290; 295; 300; 305; 310; 315; 320; 325; 330; 335; 340; 345; 350; 355; 360	M8	4.5	15	14	4
14xL	14		M12		20	17	6
16xL	16		M16		23	19	6
18xL	18		M20		28	24	8
22xL	22		M24	32	30		
25xL	25		M30	5.5	32	32	10
28xL	28				36	41	
32xL	32				37	46	
36xL	36				43	50	12
38xL	38		M36	43	50		
40xL	40		M42	5.5	52	60	15
42xL	42				59	70	
45xL	45		M48	59	70		
50xL	50		M56	5.5	67	85	15
56xL	56						
60xL	60						
65xL	65						
70xL	70						

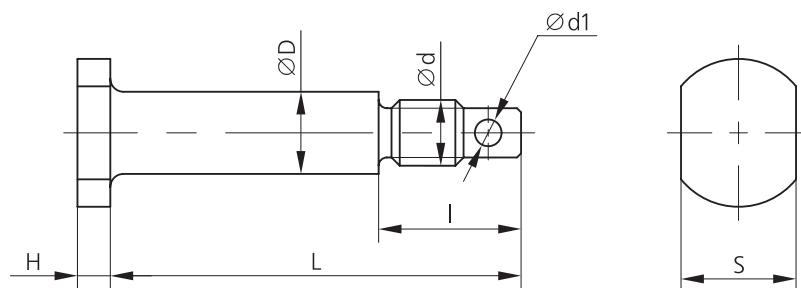

Stay clamp for towers

2-wedge clamp is intended for fastening the backstay cable for towers. Is applied with cables of 15.0, 16.0, 17.0 and 18.5 mm in diameter. Weight – 21.7 kg.

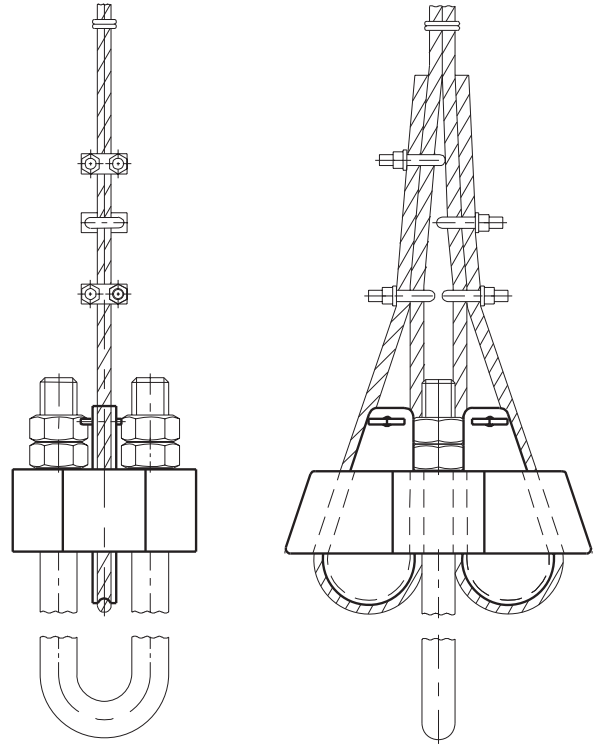

Clamp installation chart

Mounting fixture of MI-363 type

Mounting fixture of MI-363 type is intended for lifting suspension insulating strings to towers in 1150 kV power lines. Minimum failing load – 150 kN. Weight – 40.6 kg. Mounting fixture meet TU 3413.10304-90 requirements.

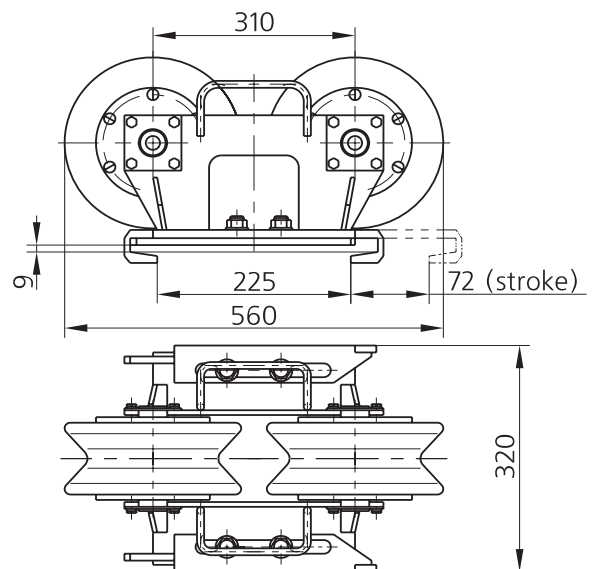
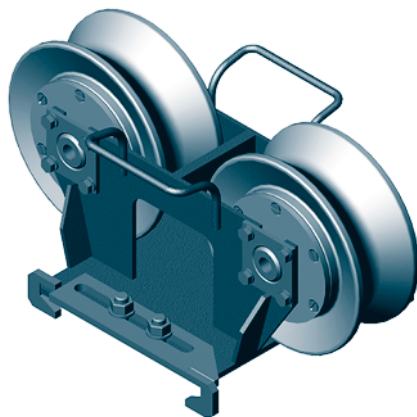

GLOBAL INSULATOR GROUP

tel +371-676-51117
e-mail: ved@gig-group.com
www.gig-group.com

